



# Landscape Inspiration Catalog



2019

COUNTY MATERIALS CORPORATION

2019 LANDSCAPE INSPIRATION CATALOG – CSI DIV : 321400, 323223 and 077616





Elements Paving Stones – Haven and Reflection (border)  
with County Block Jumbo Retaining Wall Units – Hickory Blend,  
and Crest Bullnose Pavers – Reflection



# Landscape Inspiration Catalog

## 2019



Rib Rock Landscape Block – Gray (Rough)



Summit Stone Landscape Units – Haven

### Contents

<b>Introduction.....</b>	<b>2</b>
Face-mix Technology .....	3
Landscape Product Technical Data .....	4
Warranty Information .....	9
Landscape Product Colors .....	10
Resources, Events & Education .....	12
<b>Pavers, Slabs &amp; Patio Stones .....</b>	<b>15</b>
Elements™ Paving Stones .....	17
Tranquility® Pavers .....	27
Grand Milestone® Pavers .....	33
Destination® Pavers .....	39
Lifestyle® Pavers & Grand Lifestyle® Pavers .....	45
Essence™ Wood Grain Plank Pavers .....	51
Skylands™ Concrete Deck Pavers .....	55
Crest™ Bullnose Pavers .....	61
Permeable Pavers .....	65
H <sub>2</sub> O Pro® Pavers Permeable Paving Units .....	67
Renewable™ Pavers Permeable & Sandset .....	73
Harmony™ Permeable Pavers .....	77
Paver Borders & Accents .....	81
Related Paver Items (Including Bullet Pavers and Patio Stone) .....	83
<b>Retaining Walls, Garden Seat Walls &amp; Step Units .....</b>	<b>87</b>
Rib Rock™ Landscape Block .....	89
Tribute® Retaining Wall System .....	95
County Block® Retaining Wall System .....	103
Integrity™ Retaining Wall System .....	109
Winston® Retaining Wall System .....	115
Terrace Stone® Retaining Wall System .....	121
Navaro® Retaining Wall System .....	127
County Cub® Landscape Units .....	133
Landscape Step Units .....	137
Oversize Landscape Step Units .....	141
Wall Caps and Related Retaining Wall Items .....	145
Summit Stone® Landscape Units (See Outdoor Living Products section) .....	149
<b>Outdoor Living Products.....</b>	<b>147</b>
Summit Stone® Landscape Units .....	149
Reflection Stone® Masonry Units .....	159
Isokern Fireplace, Oven and Chimney Products .....	166
Fire Pit Products .....	153 and 167
<b>Landscape Stone .....</b>	<b>169</b>



# Partner with an Experienced Manufacturer

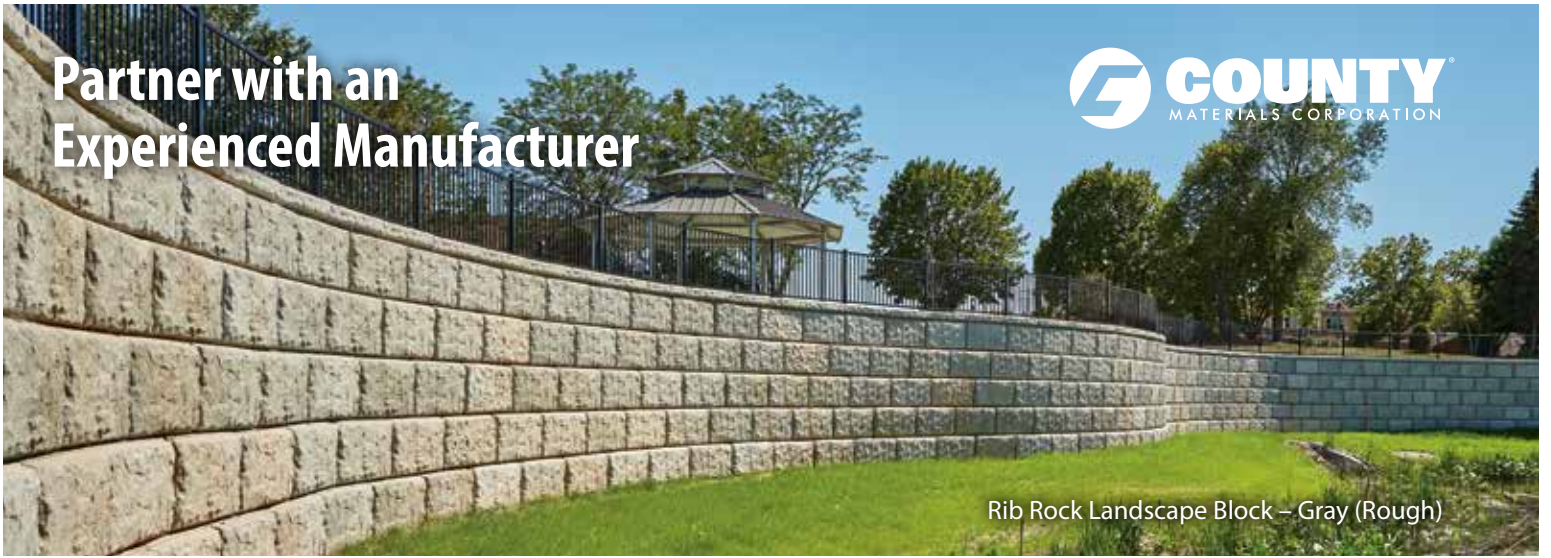

Rib Rock Landscape Block – Gray (Rough)

Since starting with a single block machine in 1946, our family-owned, American-based company has grown to be a leader in the concrete construction and landscape products industry. Today we employ a team of 1,500 dedicated people, operate more than 40 locations in six states, and distribute our products nationwide.

With County Materials as your partner, you can design and build outdoor spaces using trusted products that are specified by industry professionals around the United States. As a result, our products are part of growing communities and projects of all sizes, including infrastructure, transportation, commercial, municipal, agricultural, and residential applications.

## Leading by Example

As a strong supporter of industry education, County Materials hosts trainings and seminars, including ICPI certifications, NCMA certifications and AIA/CES learning unit presentations.



## Showcasing Real-life Project Applications

This catalog is designed with you in mind. The pages are filled with project applications that have been installed by our customers around the country.

We invite you to look through our comprehensive landscape offerings to learn more, and visit us online at [www.countymaterials.com](http://www.countymaterials.com).



H<sub>2</sub>O Pro Pavers – Timeless



## Creating Distinctive Hardscape Products with Unmatched Advantages

Our inherently strong and superior performing concrete paving stones and slabs are crafted using face-mix technology. The upper portion of each concrete paver features a permanent blend of our high-strength concrete comprised of vibrant color pigments and surface materials that results in a fine finish. This advanced and automated process concentrates the purest color pigments, finest aggregates and dense concrete mix in the top surface layer of each paving stone where it is visible and matters most. Larger aggregates in the base mix impart added strength that meets ICPI and ASTM standards.

Our commitment to manufacturing excellence doesn't stop with surface beauty. Our pavers and slabs repel stains and withstand every day wear and tear, offering lasting durability, from light pedestrian to heavy vehicular applications.

Their high strength, combined with non-fading colors and natural beauty will stand the test of time. They possess extremely accurate dimensional tolerances, higher surface density, and absorption and abrasion resistance. Our pavers are further enhanced by their appealing and sought after aesthetics, unique to North America.

County Materials began as a concrete block manufacturer more than 70 years ago. As a result, we have acquired extensive knowledge, experience, and manufacturing capabilities for segmental retaining wall units. Our retaining wall systems are ideal solutions for diverse and challenging applications. This includes residential garden walls, raised patios, pillars or seat walls to light commercial and even impressive engineered walls that provide effective soil retention and multi-level terracing advantages. Additionally, all of our wall products compliment our pavers and slab series for cohesive, integrated outdoor spaces.

## Face-mix Technology

*Fine aggregates and a dense concrete mix are concentrated in the top surface to provide a smooth, refined surface.*

*Pure color pigments and fine aggregates blended on the surface provide vibrant, rich looking and long-lasting color.*

*Our face-mix is integrally bonded to the base mix offering exceptional durability combined with outstanding aesthetics for any application.*

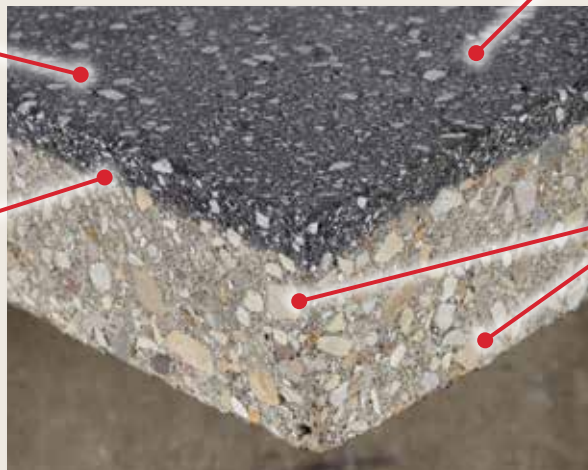

*The base concrete mix features larger aggregates for high compressive strength.*

- Made of high strength concrete, high density units resist cracking and damage from freeze-thaw cycles.
- County Materials pavers and slabs are manufactured to meet industry standards for strength, absorption, and are backed by our customer warranty.



**Proud to be American based  
and American made since 1946**





## Color Selection

Colors shown may vary from actual hues and should only be used as a guide. Refer to actual product samples for final color selection. Because concrete products are manufactured with high quality, naturally-mined aggregates and materials, variations in color or shading should be expected in products that are manufactured at different times and in units having different shapes. This color or shading variation is acceptable in the industry. County Materials recommends immediately verifying the product and color upon receipt, and prior to opening pallets. For any discrepancies, contact your local County Materials representative before installation. Use of product constitutes acceptance.

## Proper Color Distribution and Installation

Color of concrete products may vary significantly between production lots. Install concrete units from several pallets to ensure distribution of color. The contractor must install concrete units in accordance with the landscape industry's best practices according to ICPI and NCMA Standard Specifications and the manufacturer's instructions. County Materials is not liable or responsible for loss or damage resulting from improper use, handling or failure to follow installation instructions. Follow all applicable warnings, advisories, and instructions.

## Efflorescence

Efflorescence is a naturally occurring process in all concrete products which may appear in the form of a white powdery film on the unit's surface. Efflorescence may be more perceivable in darker colors. It does not, in any way, compromise the functionality or the structural integrity of the product or your installation. Although

efflorescence cannot be prevented, it will wash off over time or it can be cleaned with an industry cleaner. County Materials accepts no responsibility or liability for the occurrence of efflorescence.

## Joint Material

There are many different jointing materials specific to application requirements and desired results. Joint material should be completely removed from the surface of the pavers. ASTM C144 specifies natural sand as the paver jointing material for use with County Materials' concrete pavers, along with a sand joint stabilizer. Polymeric sands should not be used on pavers with heavily textured surface. Use of joint material must comply with all instructions provided by the joint material manufacturer, and the joint material method must be performed on a separate mock-up sample not less than 7 feet by 7 feet prior to Buyer approval. County Materials accepts no responsibility or liability for the use of joint material with our concrete pavers.

## Polymeric Haze

Polymeric haze from the use of polymeric joint sand may appear on concrete paver products if the sand was not installed properly or removed from the surface of the pavers properly. This does not, in any way, compromise the functionality or the structural integrity of the product or your installation. The hazing will weather away naturally with time and rain. Polymeric haze may be removed with an industry cleaner. County Materials accepts no responsibility or liability for the use of polymeric sand with our concrete pavers or any occurrence of polymeric haze or other undesired result.



## Washing Guidelines

Seasonal maintenance is recommended for all County Materials pavers and slabs. General washing guidelines are provided for the following: organic stains, including fruit, soil and leaf residue, algae and moss stains, and efflorescence. For efflorescence stains, wash with a hose and stiff broom or pressure washer. Care must be taken if pressure washing is done to avoid removing excess joint sand or damaging paving material. Water pressure should be comparable to the average pressure from a home watering hose.

## Cleaning Agents

Concrete cleaning agents are not required but are an option for all County Materials pavers and slabs. There are many different cleaning agents specific to application requirements and desired results. Use of the cleaning agent must comply with all instructions provided by the cleaning agent manufacturer, and the cleaning agent method must be performed on a separate mock-up sample not less than 7 feet by 7 feet prior to Buyer approval. County Materials accepts no responsibility or liability for the use of cleaning agents on our pavers and slabs.

## Sealers

A concrete sealer application is not required on County Materials pavers and slabs but is an option. There are many different sealing agents specific to application requirements and desired results. Use of the sealing agent must comply with all instructions provided by the sealing agent manufacturer, and the sealing agent method must be performed on a separate mock-up panel not less than 7 feet by 7 feet prior to Buyer approval. County Materials accepts no responsibility or liability for the use of sealers on our pavers and slabs.

## Construction Residue

A possible by-product of cutting concrete units during installation with a saw is residue-filled water or concrete dust. Residue-filled water or re-hydrated dust can cling to the surface of units and leave a concrete stain. It is recommended to wash and remove the water or concrete dust from the surface of the pavers before it dries. Construction residue can also happen through soil disturbance or environmental elements. These contaminants should be removed immediately; they do not compromise the functionality or the structural integrity of the product or your installation. County Materials accepts no responsibility or liability for the occurrence of construction residue or concrete stains.

## Compactor and Snow Removal Equipment

Textured paver and patio stone surfaces require a buffer between the plate compactor and the paver surface to prevent scuffing. Refer to County Materials' Interlocking Concrete Paver or Slab Installation Guidelines. Also, snow removal equipment should have the proper spacing, bumper, and rubber blade guards to protect the surface of the pavers. County Materials accepts no responsibility or liability for damage caused by the use of compaction or snow removal equipment that may leave scuffs, burns or other markings on pavers.





# Landscape Product Technical Data



Grand Lifestyle Pavers – Haven  
and Summit Stone Landscape Units – Haven

## ASTM Guidelines for Interlocking Concrete Pavers and Slabs

County Materials provides general construction guidelines to design professionals and installers of interlocking concrete pavers and concrete slabs. For additional installation information, reference the Interlocking Concrete Pavement Institute’s (ICPI) Tech Spec Technical Bulletins.

All interlocking concrete pavers manufactured by County Materials are manufactured in general accordance with industry guidelines.

Characteristics	ASTM C936
Compressive strength	8000 psi at 28 days
Durability to freeze thaw cycles	Total mass loss after 50 cycles, no greater than 1%
Water absorption	Lower than 5%
Dimension tolerance	± 3 mm (1/8”) Height ± 1.58 mm (1/16”) Length and width

All concrete slabs manufactured by County Materials Corporation are manufactured in general accordance with the following industry guidelines:

Characteristics	ASTM C1782 & C140
Flexural Strength	725 psi (min.)
Freeze-thaw durability with use of de-icing salt	Loss of 225g/m <sup>2</sup> max. at 28 cycles Loss of 500g/m <sup>2</sup> max. at 49 cycles
Water absorption	6% (max.)
Dimension tolerance	± 3 mm (1/8”) Height ± 2 mm (5/64”) Length and width
Warpage	± 3 mm (1/8”)



# Landscape Product Technical Data



County Block Retaining Wall System – Swiss Mocha  
with Summit Stone Landscape Units – Haven

## ASTM C1372 Standard Specifications for Segmental Retaining Wall Units

County Materials provides general construction guidelines to design professionals and installers of concrete retaining wall units. For additional information, reference the National Concrete Masonry Association’s (NCMA) SRW Installation Guide.

All concrete retaining wall units manufactured by County Materials are manufactured in general accordance with the following industry guidelines.

<b>Strength and Absorption Requirements (ASTM)</b>		
<b>Minimum Required Net Average Compressive Strength, psi (MPa)</b>		
Average of 3 Units 3000 (20.7)	Individual Unit 2500 (17.2)	
<b>Maximum Water Absorption Requirements</b>		
<b>Weight Classification Oven-Dry Density of Concrete lb/ft<sup>3</sup> (kg/m<sup>3</sup>)</b>		
Light Weight Less than 105 (1682) 18 (288)	Medium Weight 105 (1682) to less than 125 (2002) 15 (240)	Normal Weight 125 (2002) or more 13 (208)

**Freeze-thaw Durability:** In areas where repeated freezing and thawing under saturated conditions occur, freeze-thaw durability is required to be demonstrated by test or by proven field performance. When testing is required, the units are required to meet the following

when tested in accordance with ASTM C1262, Standard Test Method for Evaluating the Freeze-Thaw Durability of Manufactured Concrete Masonry Units and Related Concrete Units.





Tranquility Pavers – Haven (with border of Elements Paving Stones – Reflection), Summit Stone Landscape Units – Haven and Timeless, and Crest Bullnose Pavers – Vision



## Warranties for Concrete Hardscape Products

County Materials works continuously to provide value to our customers and enhance our manufacturing capabilities, all while surpassing our high standards of excellence. We manufacture our hardscape products to meet the industry's standards. That is why we back our hardscape products with an exclusive limited Warranty.

### County Materials **PAVER** Products Warranty

COUNTY MATERIALS CORPORATION'S CONCRETE PAVERS MEET THE REQUIREMENTS OF APPLICABLE ASTM STANDARD(S). COUNTY MATERIALS WARRANTS ITS CONCRETE PAVERS AGAINST MANUFACTURING DEFECTS FOR THE PERIOD OF YOUR RESIDENTIAL HOME OWNERSHIP. FOR COMMERCIAL PROJECTS, COUNTY MATERIALS WARRANTS ITS CONCRETE PAVERS AGAINST MANUFACTURING DEFECTS FOR 5 YEARS AFTER SUBSTANTIAL COMPLETION OF THE PROJECT. THIS WARRANTY IS NON-TRANSFERABLE. THIS LIMITED WARRANTY DOES NOT APPLY TO DAMAGE CAUSED BY IMPROPER STORAGE, ABRASION, OVERLOADING, OR MISUSE, SUCH AS DELAMINATION, SPLITTING, CHIPPING, OR STAINING. THIS LIMITED WARRANTY APPLIES ONLY IF THE PRODUCTS ARE INSTALLED AS DIRECTED BY THE ICPI ([WWW.ICPI.ORG](http://WWW.ICPI.ORG)) AND COUNTY MATERIALS' APPLICABLE INSTALLATION GUIDELINES. IMPROPER INSTALLATION VOIDS THIS LIMITED WARRANTY. THE ORIGINAL PROOF OF PURCHASE IS NECESSARY. COLOR MATCHING CANNOT BE GUARANTEED. THE FOREGOING LIMITED WARRANTY IS IN LIEU OF AND EXCLUDES ALL OTHER WRITTEN OR ORAL WARRANTIES, INCLUDING THE IMPLIED WARRANTIES OF FITNESS FOR A PARTICULAR PURPOSE AND MERCHANTABILITY. CUSTOMER'S EXCLUSIVE REMEDY FOR BREACH OF THE ABOVE LIMITED WARRANTY IS LIMITED TO COUNTY MATERIALS REPLACING THE PRODUCTS AT NO COST TO THE ORIGINAL CUSTOMER. COUNTY MATERIALS' LIABILITY FOR BREACH OF THE ABOVE LIMITED WARRANTY SHALL NOT EXCEED THE PRICE OF THE PRODUCTS ACTUALLY RECEIVED BY CUSTOMER AND DOES NOT INCLUDE REPLACEMENT LABOR, CONSEQUENTIAL DAMAGES, OR INCIDENTAL DAMAGES.

### County Materials **RETAINING WALL** Products Warranty

**EXCLUSIVE LIMITED WARRANTY:** Seller warrants that stock Products, to the extent they are manufactured by Seller, shall be free from manufacturing defects in materials and workmanship and meet the description and specifications established in Seller's published and internal standards (subject to reasonable variance in accordance with normal industry practice) for a period of thirty (30) days from delivery, and all other warranties are expressly disclaimed as described in the capitalized sentence below. Seller may, in its sole discretion, also rely on any generally accepted industry standards. Seller retains the right, however, to change the dimensions, composition, design, performance, color, and appearance of the Products without liability if, in Seller's judgment, the change is non-material. Seller warrants that non-stock Products manufactured by Seller meet only those specifications and standards provided by Buyer for a period of thirty (30) days from delivery, all other warranties are expressly disclaimed as described in the capitalized sentence below, and Buyer understands that that harmful cracking or other damage may occur if the Product specifications are not properly designed. Seller does not warranty any portion of Products not manufactured by Seller but Seller shall assign to Buyer, upon request, all assignable warranties of Seller's suppliers related to such Products. Acceptance by Buyer of the Products constitutes confirmation that Products meet the description set forth above. THE FOREGOING WARRANTY IS IN LIEU OF AND EXCLUDES ALL OTHER WRITTEN OR ORAL WARRANTIES, INCLUDING THE IMPLIED WARRANTIES OF FITNESS FOR A PARTICULAR PURPOSE AND MERCHANTABILITY, WHETHER EXPRESS OR IMPLIED BY LAW, INCLUDING THE UNIFORM COMMERCIAL CODE AS ENACTED IN THE STATE OF WISCONSIN OR ELSEWHERE. This limited warranty only applies if the Products have not been subjected to misuse, negligence, or accident and have not been unloaded, stored, installed, maintained, altered, or repaired in any manner that, in the Seller's judgment, adversely affects the condition or operation of the Products. Further, the foregoing limited warranty and the exclusive remedy below run only in favor of the original Buyer and may not be assigned or otherwise transferred.

**EXCLUSIVE REMEDY:** For any loss or damage arising out of supplying Products to Buyer, or the sale, operation, or use of the Products—whether such claim is based in contract, warranty, tort (including negligence) or other grounds—BUYER'S EXCLUSIVE REMEDY IS LIMITED, at Seller's sole discretion, to either: (1) refund by the Seller of the purchase price for any non-conforming Products sold hereunder; or (2) the repair or replacement of any non-conforming Products. UNDER THIS EXCLUSIVE REMEDY, BUYER SHALL NOT RECOVER ANY OTHER COSTS FROM THE SELLER, including but not limited to the costs for: return of non-conforming Products, delivery of replacement Products, removal of non-conforming Products, reinstallation of replacement Products (or products purchased to replace any non-conforming Products), and/or any labor charges incurred related to the Products. NO OTHER REMEDY SHALL BE AVAILABLE TO BUYER. ANY CLAIM FOR INCIDENTAL AND/OR CONSEQUENTIAL DAMAGES for lost profits, lost sales, injury to property, or any other incidental or consequential loss IS THEREFORE BARRED PURSUANT TO THE TERMS OF THIS EXCLUSIVE REMEDY. Seller will not be liable for any failure of Products to conform to the Exclusive Limited Warranty above caused by the unloading, storage, installation, or maintenance of the Products, or use of other products/materials in conjunction with the Products that negatively impact the Product or otherwise do not conform with industry standards. The above limitations do not include damages related to personal injury.



# Landscape Product Colors

● Available    ○ Manufactured On Demand    ● Manufactured by Special Order

Pavers & Slabs	Solid Colors						Blended Colors								
	Dream	Homecoming	Reflection	Reunion	Traditions	Vision	Haven	Oasis	Serenity	Timeless	Calm	Aware	Bliss	Pride	Majestic
<b>Elements™ Paving Stones</b>															
Standard	●	●	●	●	●	●	●	●	●	●	●				●
Rustic	○	○	○	○	○	○	○	○	○	○	○				○
Barrel Tumbled	○	○	○	○	○	○	○	○	○	○	○				○
Rustic Shotblast	○	○	○	○	○	○	○	○	○	○	○				○
Rough Estate	●	●	●	●	●	●	●	●	●	●	●				●
Shotblast	○	○	○	○	○	○	○	○	○	○	○				○
<b>Tranquility® Pavers</b>															
Standard							●	●	●	●	●				●
Rustic							○	○	○	○	○				○
<b>Grand Milestone® Pavers</b>															
Standard							●	●	●	●	●				●
Rustic							○	○	○	○	○				○
<b>Destination® Pavers</b>															
Standard							●	●	●	●					●
<b>Lifestyle® Pavers and Grand Lifestyle® Pavers</b>															
Standard							●	●	●	●					●
Rustic							○	○	○	○					○
<b>Essence™ Wood Grain Plank Pavers</b>															
Standard										●		●	●	●	
<b>Skylands™ Concrete Deck Pavers</b>															
Standard	●	●	●	●	●	●	●	●	●	●					●
Rustic	○	○	○	○	○	○	○	○	○	○					○
Shotblast	○	○	○	○	○	○	○	○	○	○					○
<b>Crest™ Bullnose Pavers</b>															
Standard			●			●	●	●	●	●					
Barrel Tumbled			●			●	●	●	●	●					

Permeable Pavers	Solid Colors						Blended Colors								
	Dream	Homecoming	Reflection	Reunion	Traditions	Vision	Haven	Oasis	Serenity	Timeless	Enduring	Paradise	Peace	Sanctuary	Majestic
<b>H<sub>2</sub>O Pro® Pavers Permeable Paver System</b>															
Standard			●			●	●	●	●	●					●
Rustic			●			●	●	●	●	●					●
Barrel Tumbled			●			●	●	●	●	●					●
Rustic Shotblast			●			●	●	●	●	●					●
Rough Estate			●			●	●	●	●	●					●
<b>Renewable™ Pavers Permeable Paver System &amp; Sandset Pavers</b>															
Standard	●	●	●	●	●	●	●	●	●	●					●
Rough Estate	●	●	●	●	●	●	●	●	●	●					
<b>Harmony™ Permeable Pavers</b>															
Standard	●	●	●	●	●	●					●	●	●	●	●

**NEW Color for 2019!**

**NEW Color for 2019!**



Retaining Walls	Solid Colors					Blended Colors									
	Brown	Buff	Gray	Natural Gray	October Oak	Canyon Brown	Desert Vista	Haven	Hickory Blend	Hush	Rio Grande	Serenity	Silverstone	Swiss Mocha	Timeless
<b>Rib Rock™ Landscape Block</b>															
Standard				•											
<b>Tribute® Retaining Wall System</b> Appleton, WI															
Standard	•	•	•			•			•				•	•	
<b>Tribute® Retaining Wall System</b> Roberts, WI															
Standard	•	•	•		•	•			•				•	•	
Rustic	•	•	•		•	•			•				•	•	
<b>County Block® Retaining Wall System</b> Appleton, WI															
Standard	•	•	•			•			•				•	•	
<b>County Block® Retaining Wall System</b> Marathon, WI															
Standard	•		•			•			•				•		
<b>County Block® Retaining Wall System</b> Roberts, WI															
Standard	•	•	•			•			•				•	•	
Rustic/Heavy Rustic	•												•		
<b>Winston® Retaining Wall System</b>															
Standard	•		•			•							•		
<b>Integrity™ Retaining Wall System</b>															
Standard		•	•					•		•		•			•
Rustic		•	•					•		•		•			•
Heavy Rustic		•	•					•		•		•			•
<b>Terrace Stone® Retaining Wall System</b>															
Standard	•		•			•							•		
<b>Navaro® Retaining Wall System</b>															
Standard	•		•			•			•				•		
<b>County Cub® Landscape Units</b>															
Standard	•		•			•	•		•		•		•		

Retaining Wall Caps are available in all retaining wall product lines.

Outdoor Living Products	Solid Colors					Blended Colors								
	Vision	Reflection	Clarity	Devotion	Enchantment	Haven	Hush	Inspired	Noble	Promise	Pure	Solace	Stillness	Timeless
<b>Summit Stone® Landscape Units</b>														
Smooth	•	•				•	•					•		•
Tumbled						•	•					•		•
<b>Reflection Stone®</b>														
Standard			•	•	•			•	•	•	•		•	
Rustic			•	•	•			•	•	•	•		•	
<b>Reflection Stone® GRAND</b>														
Standard			•	•	•			•	•	•	•		•	
Rustic			•	•	•			•	•	•	•		•	
<b>Reflection Brick®</b>														
Standard			•	•	•			•	•	•	•		•	
Rustic			•	•	•			•	•	•	•		•	



# Resources, Events & Education



## Resources

For additional product information including technical data, specifications, or specific product brochures and catalogs, visit our Resources on our website at [www.countymaterials.com](http://www.countymaterials.com).

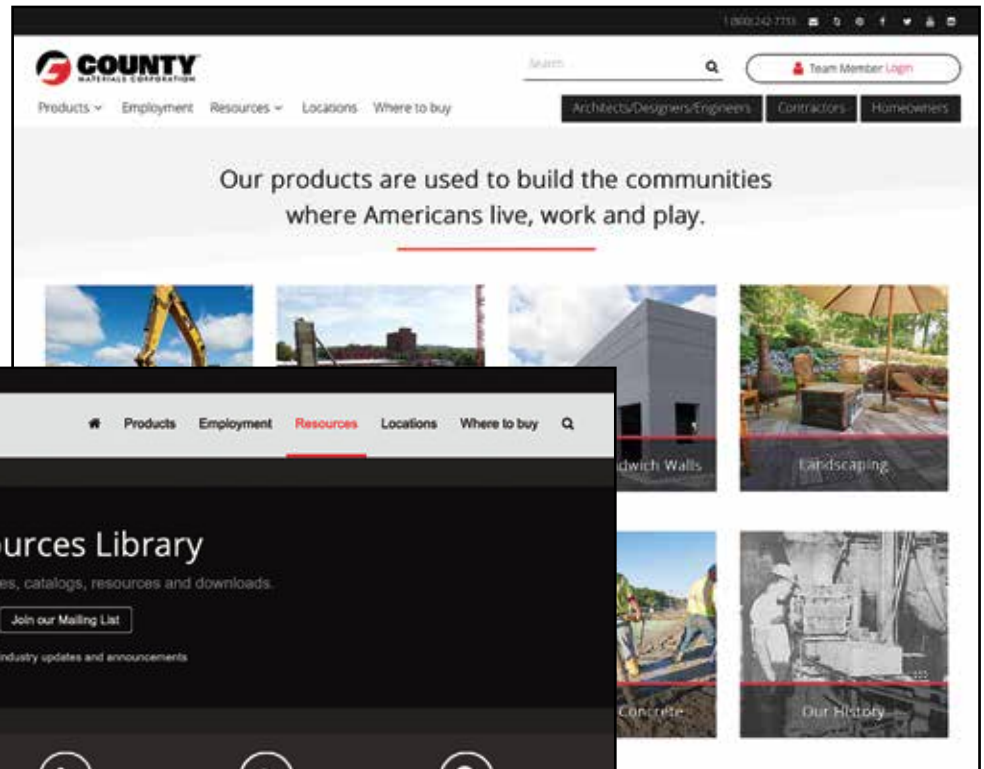

## Product Specifications on ARCAT

County Materials posts product specifications on ARCAT. Find County Materials' Product Specifications by clicking on our Resources Library.



## Product CAD Details

County Materials offers product CAD details on ARCAT that can easily be downloaded, customized for your residential or commercial project, and included in your CAD library for future use. Click on our Resources library to access them.





## SRW Engineered Retaining Wall Manuals

We offer Engineered Retaining Wall Manuals by Hardscape Technical Services for our line of engineered retaining wall systems. Contact your local County Materials representative on how to obtain one of these manuals or go online to our Resources page where you can download one for free under Product Installation & Maintenance Guides.

- County Block® Retaining Wall System
- County Block® Jumbo Retaining Wall System
- Rib Rock™ Landscape Block
- Tribute® Retaining Wall System
- Integrity™ Retaining Wall System



## Events & Education

County Materials periodically sponsors or hosts various seminars, events or tradeshows aimed at educating contractors, architects and engineers on hardscape products and practices.

More project owners and construction professionals are requiring hardscape contractors to fulfill and maintain industry-approved training credentials because they recognize the value of using professionals who stand behind their workmanship and uphold industry standards. County Materials actively supports and sponsors industry training and education for professional hardscape contractors to improve the quality of interlocking and permeable paver and retaining wall installations.

Additionally, County Materials provides a variety of industry resources designed to strengthen sales and enhance workmanship to a higher professional level. Improving the quality of paver and retaining wall installations is a win-win for contractors and our industry. Details are available by talking to your County Materials representative, contacting our Customer Service Department at (800) 242-7733 or e-mail us at [info@countymaterials.com](mailto:info@countymaterials.com).

### AIA/CES and LA/CES Continuing Education for Credit Seminars

County Materials Corporation, and our industry associate AIA/CES Providers, offer several AIA/CES and LA/CES approved courses for architects, landscape architects, engineers, developers and builders interested in learning more about diverse construction products. Instructors will set up at your work place and provide a complimentary lunch to all program attendees.

#### Available Courses:

- Concrete Roof Deck Paver System
- Burnished Concrete Masonry
- Decorative Concrete Face & Thru Wall-Load Bearing Brick
- Permeable Paver Design & Performance III
- Concrete Pavers in Commercial Applications
- Concrete Thin Veneers –  
The Advantages of Concrete Thin Veneers
- Concrete Masonry Veneer Units
- County Materials Block and Paver Plant Tour

Additional learning seminars are offered to construction and masonry industry professionals. Please contact your County Materials Representative for more information.



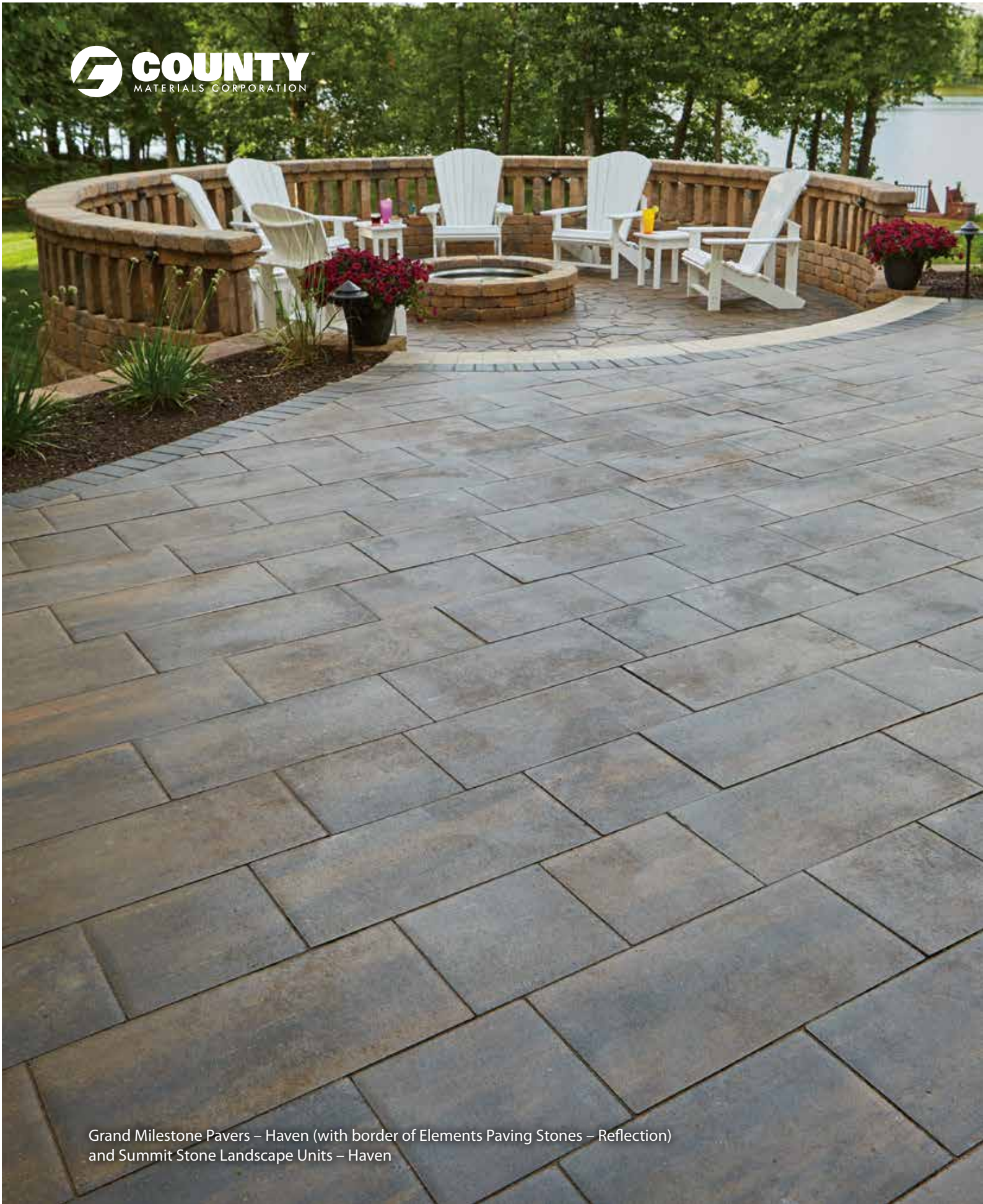

Grand Milestone Pavers – Haven (with border of Elements Paving Stones – Reflection)  
and Summit Stone Landscape Units – Haven





# Pavers, Slabs & Patio Stones

- Elements™ Paving Stones
- Tranquility® Pavers
- Grand Milestone® Pavers
- Destination® Pavers
- Lifestyle® Pavers & Grand Lifestyle® Pavers
- Essence™ Wood Grain Plank Pavers
- Skylands™ Concrete Deck Pavers
- Crest™ Bullnose Pavers
- H<sub>2</sub>O Pro® Pavers Permeable Paving Units
- Renewable™ Pavers Permeable & Sandset
- Harmony™ Permeable Pavers
- Paver Border & Accents

## Related Paver Items:

- Grass Pavers
- Smooth Round Patio Stones
- Smooth Square Patio Stones
- Brickface Patio Stones
- Veranda & Courtyard Patio Stones
- Patio Block
- Bullet Edgers
- Paver Sand
- Edging
- Cleaners & Enhancers
- Air Conditioner Pads
- Parking Curbs
- Pole Pads
- Splash Block
- Sign Post Bases

*The color photos shown in this catalog were prepared with careful attention to accuracy. However, colors shown may vary from actual hues and should only be used as a guide. Refer to actual product samples for final color selection. Because concrete units are manufactured with high quality, naturally-mined aggregates and materials, variations in color or shading should be expected in products that are manufactured at different times and in units having different shapes. This color or shading variation is acceptable in the industry.*



## Face-mix Technology



- Focused Color Pigments
- Finest Aggregates
- Dense Concrete Mix

---

- Integrally Bonded
- Compressive Strength
- Larger Aggregates



Elements Paving Stones – Haven (with border of Serenity and stamped ready-mix),  
and County Block Jumbo Retaining Wall Units – Hickory Blend



# Elements™ Paving Stones

Elements Paving Stones offer a refined appearance that seamlessly integrates into any environment.

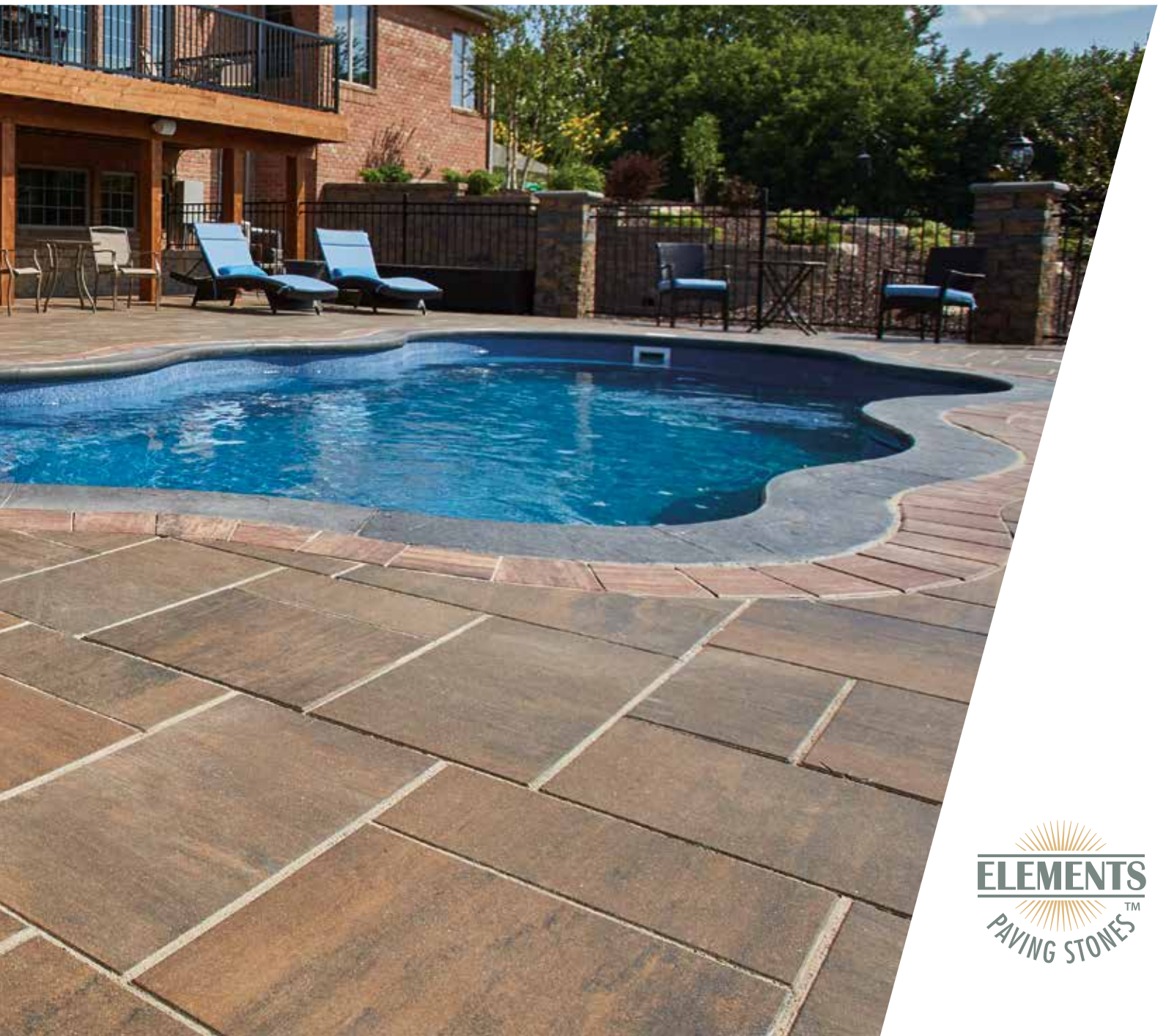

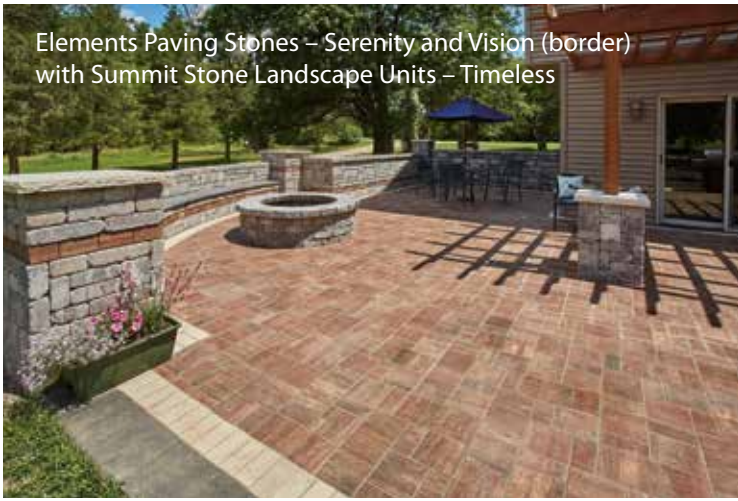

Elements Paving Stones – Serenity and Vision (border)  
with Summit Stone Landscape Units – Timeless

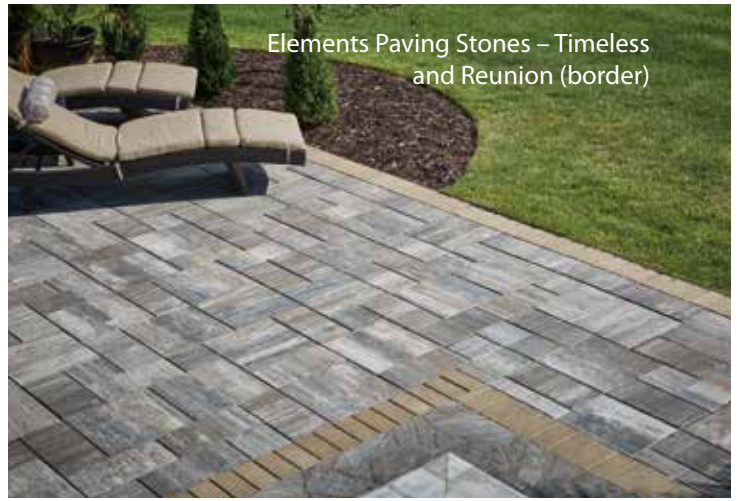

Elements Paving Stones – Timeless  
and Reunion (border)

Manufactured with superior surface durability, **Elements™ Paving Stones** have a flat surface and slightly chamfered edges that embody fine cut jewels for a feeling of ultimate luxury. Units are designed for those looking for the perfect balance between technical functionality and aesthetic appeal. Elements Paving Stones have uniform shapes and dimensionally compatible sizes to create uncomplicated presentations. Additionally, Elements Paving Stones are available in many unique color blends and surface treatments for boundless possibilities of expression and composition.

## Sizes Elements Paving Stones

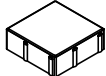
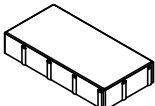
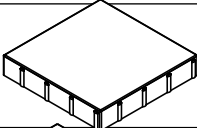
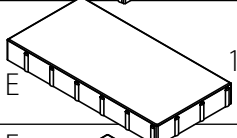
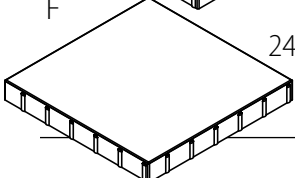
	D x H x L (Nominal Size) Inches • Millimeters	SF/Unit	Units/ SF	SF/ Layer	Layers/ Pallet	SF/ Pallet	Units/ Layer	Units/ Pallet	Lbs/ Pallet
A 	4 x 2¾ x 8 • 102 x 70 x 203	.22	4.5	11	8	88	50	400	2820
B 	8 x 2¾ x 8 • 203 x 70 x 203	.44	2.25	13.33	8	105.6	30	240	3380
C 	8 x 2¾ x 16 • 203 x 70 x 406	.89	1.13	13.33	8	106.8	15	120	3305
D 	16 x 2¾ x 16 • 406 x 70 x 406	1.78	.56	16.02	6	96.12	9	54	3080
E 	12 x 2¾ x 24 • 304 x 70 x 609	2	.5	12	8	96	6	48	3130
F 	24 x 2¾ x 24 • 609 x 70 x 609	4	.25	8	8	64	2	16	2095





Elements Paving Stones – Serenity and Vision (border)  
with Summit Stone Landscape Units – Haven

## Layer Patterns Elements Paving Stones

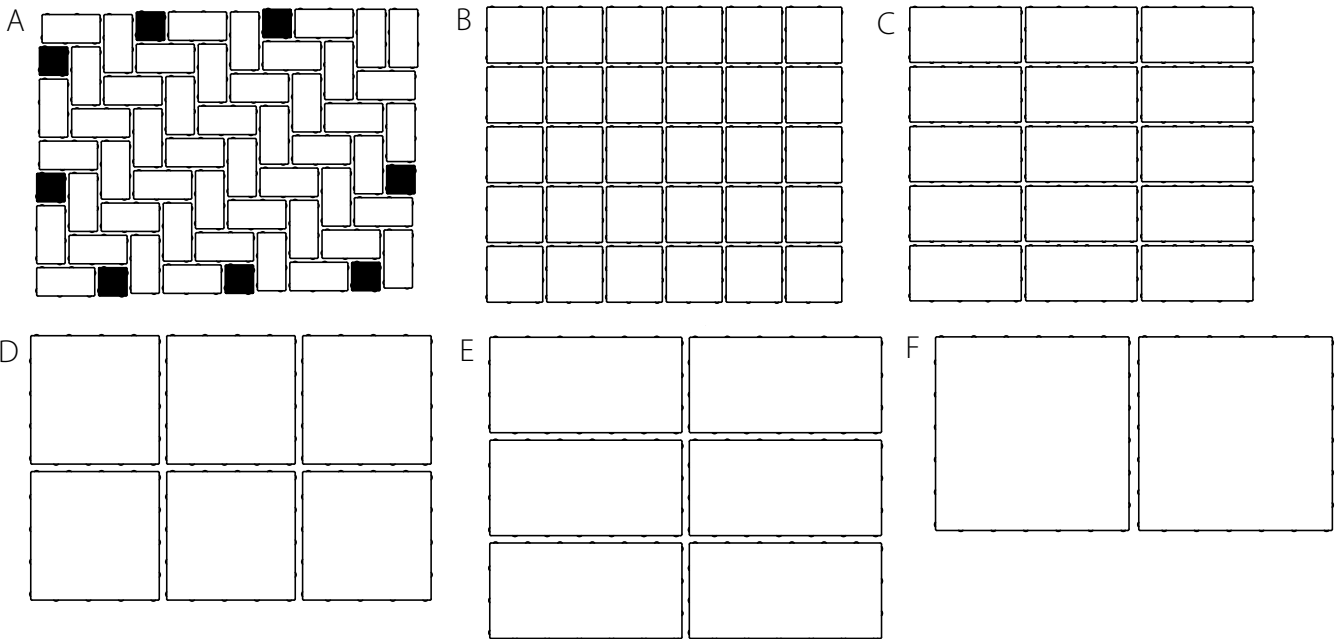

**Note:** 4" x 4" fillers (see black squares in illustration for layer pattern "A") are used to keep the integrity of a layer when placed by a machine. They are no charge and not sold separately. If 4" x 4" fillers are used in a pattern and more are needed, installers can cut 4" x 8" pavers in half and install where needed.

**Note:** Because of our Shotblast process, the layer pattern on a pallet of Shotblast pavers will not match the layer pattern as illustrated. Shotblast pavers also include (8) 4" x 4" fillers in each layer. The fillers are no charge and not sold separately. If fillers are used in a pattern and more are needed, installers can cut 4" x 8" pavers in half and hammer them to get the Shotblast look.

# Installation Patterns Elements Paving Stones

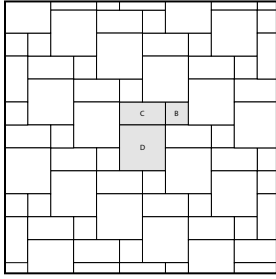

B, C & D Units Pattern #1  
B-14% C-29% D-57%

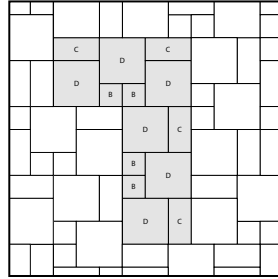

B, C & D Units Pattern #2  
B-11% C-22% D-67%

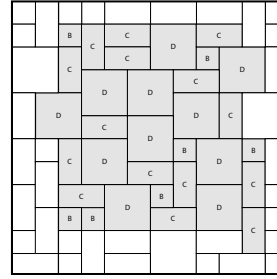

B, C & D Units Pattern #3  
B-8% C-36% D-56%

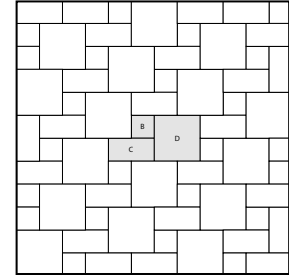

B, C & D Units Pattern #4  
B-14% C-29% D-57%

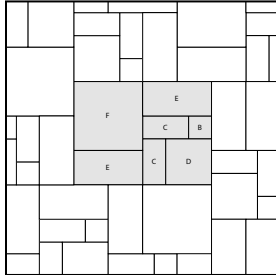

B, C, D, E & F Units Pattern #5  
B-4% C-15% D-15% E-33% F-33%

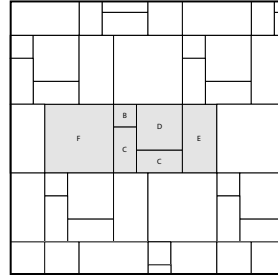

B, C, D, E & F Units Pattern #6  
B-4% C-18% D-18% E-20% F-40%

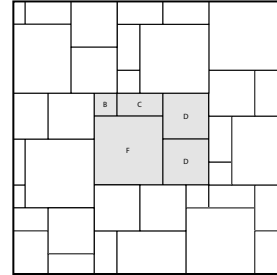

B, C, D & F Units Pattern #7  
B-5% C-10% D-40% F-45%

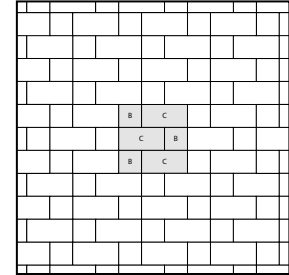

B & C Units Pattern #8  
B-33% C-67%

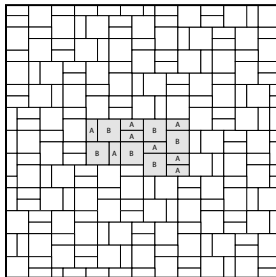

A & B Units Pattern #9  
A-40% B-60%

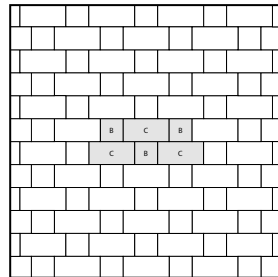

B & C Units Pattern #10  
B-33% C-67%

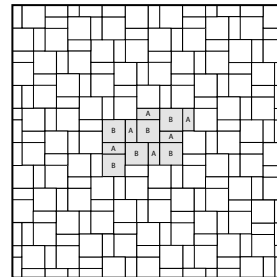

A & B Units Pattern #11  
A-33% B-67%

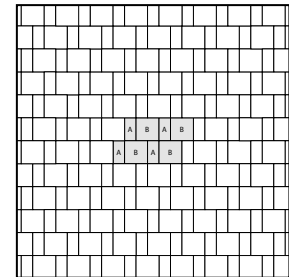

A & B Units Pattern #12  
A-33% B-67%

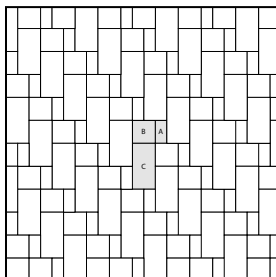

A, B & C Units Pattern #13  
A-17% B-29% C-57%

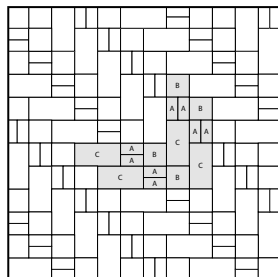

A, B & C Units Pattern #14  
A-25% B-25% C-50%

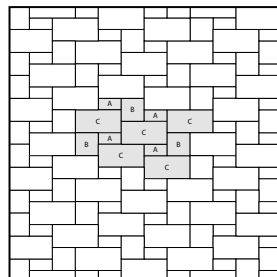

A, B & C Units Pattern #15  
A-13% B-20% C-67%

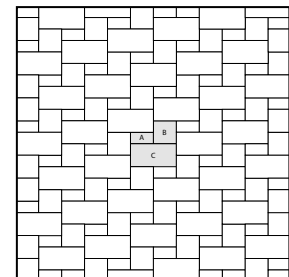

A, B & C Units Pattern #16  
A-14% B-29% C-57%

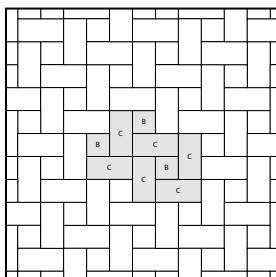

B & C Units Pattern #17  
B-20% C-80%

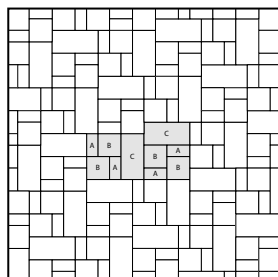

A, B & C Units Pattern #18  
A-20% B-40% C-40%

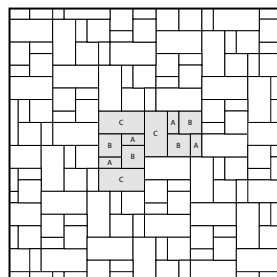

A, B & C Units Pattern #19  
A-17% B-33% C-50%

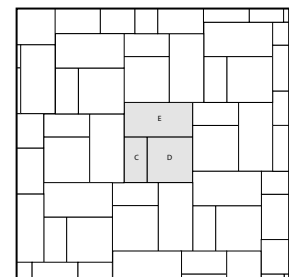

C, D & E Units Pattern #20  
C-19% D-38% E-43%



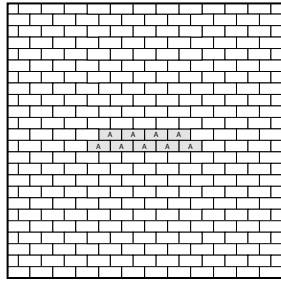

Running Bond  
A Units

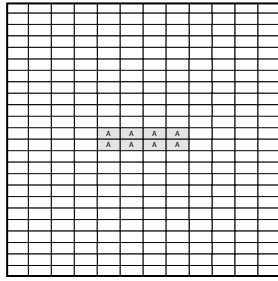

Stack Bond  
A Units

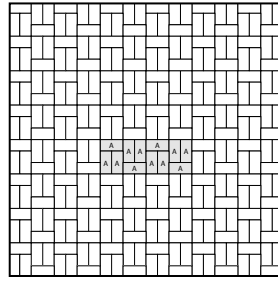

Single Basket Weave  
A Units

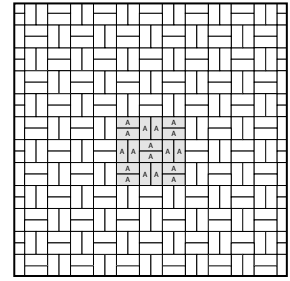

Parquet/Basket Weave  
A Units

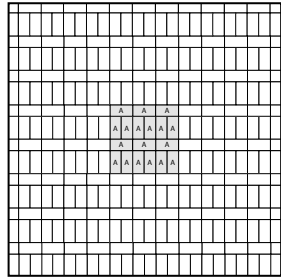

Stack Bond (Variant)  
A Units

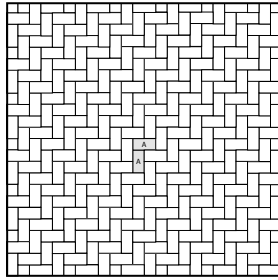

90° Herringbone  
A Units

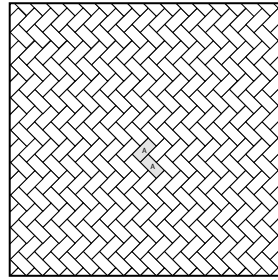

45° Herringbone  
A Units

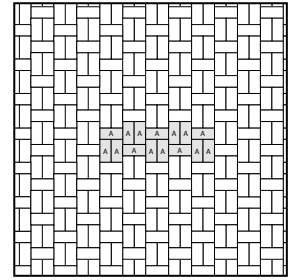

Single Offset Basket Weave  
A Units

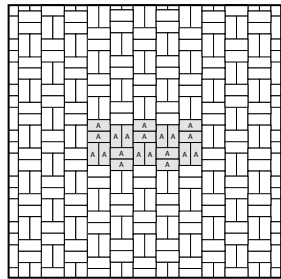























Double Offset Basket Weave  
A Units



# Color Options Elements Paving Stones

**NEW Color for 2019!**

## Blended Colors

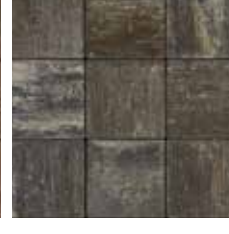













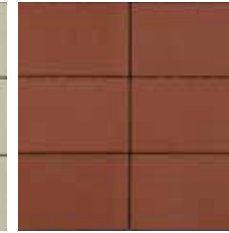

















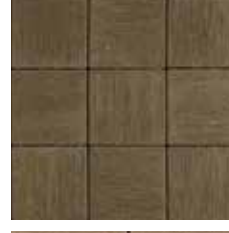

Standard						
Rustic						
Barrel Tumbled						
Rustic Shotblast						
Rough Estate					Photo Not Available	Photo Not Available
	Haven	Oasis	Serenity	Timeless	Calm	Majestic

- Standard Colors available in all 6 sizes.
- Rustic Colors are manufactured On Demand and available in all 6 sizes.
- Barrel Tumbled Colors are manufactured On Demand and available in 4"x 8", 8"x 8" and 8"x16"
- Shotblast Colors are manufactured On Demand and available in all 6 sizes (Photos not available).
- Rustic Shotblast Colors are manufactured On Demand and available in all 6 sizes.
- Rough Estate Colors are manufactured by Special Order and available in all 6 sizes.

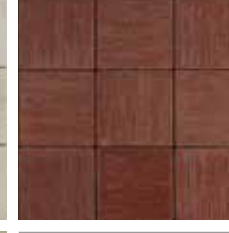
*The color photos shown in this catalog were prepared with careful attention to accuracy. However, colors shown may vary from actual hues and should only be used as a guide. Refer to actual product samples for final color selection. Because concrete units are manufactured with high quality, naturally-mined aggregates and materials, variations in color or shading should be expected in products that are manufactured at different times and in units having different shapes. This color or shading variation is acceptable in the industry.*



Solid Colors

Standard						
Rustic						
Barrel Tumbled						
Rustic Shotblast						
Rough Estate						
Shotblast						Photo Not Available
	Dream	Homecoming	Reflection	Reunion	Vision	Traditions

- Standard Colors are available in all 6 sizes.
- Rustic Colors are manufactured On Demand and available in all 6 sizes.
- Barrel Tumbled Colors are manufactured On Demand and available in 4"x 8", 8"x 8" and 8"x16"
- Shotblast Colors are manufactured On Demand and available in all 6 sizes.
- Rustic Shotblast Colors are manufactured On Demand and available in all 6 sizes.
- Rough Estate Colors are manufactured by Special Order and available in all 6 sizes.



Elements Paving Stones – Haven (with border of Serenity and stamped ready-mix),  
and County Block Jumbo Retaining Wall Units – Hickory Blend



Elements Paving Stones – Vision and Haven (border)  
with Tribute Retaining Wall System – Canyon Brown,  
Summit Stone Landscape Units – Haven  
and Crest Bullnose Pavers – Vision



Elements Paving Stones – Serenity and Reflection (border)  
with Summit Stone Landscape Units – Timeless



Elements Paving Stones – Serenity and Vision (border)  
with Summit Stone Landscape Units – Timeless



## Face-mix Technology



- Focused Color Pigments
- Finest Aggregates
- Dense Concrete Mix

---

- Integrally Bonded
- Compressive Strength
- Larger Aggregates



Tranquility Pavers – Timeless (with border of Elements Paving Stones – Reflection), Tribute Retaining Wall System – Silvertone and Crest Bullnose Pavers – Timeless



# Tranquility® Pavers

Featuring a subtle, textured surface, Tranquility Pavers embody a contemporary aesthetic reminiscent of cut mosaic tile or slate.





Tranquility Pavers – Oasis  
with border of Elements Paving Stones – Oasis  
and Oversize Landscape Step Units – Camel



**Tranquility® Pavers'** clean lines create a crisp finished look. Tranquility Pavers are a perfect choice for any outdoor application, from high-energy gatherings to calm and restful retreats. Rich color blends, a textured nonslip surface and abrasion resistance further enhances Tranquility Pavers' understated beauty and quality.

## Sizes & Patterns Tranquility Pavers

D x H x L (Nominal Size)  
Inches • Millimeters

A   $9\frac{1}{4} \times 2\frac{3}{4} \times 4\frac{5}{8}$  • 235 x 70 x 117

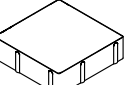
B   $9\frac{1}{4} \times 2\frac{3}{4} \times 9\frac{1}{4}$  • 235 x 70 x 235

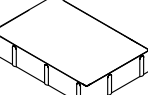
C   $14 \times 2\frac{3}{4} \times 9\frac{1}{4}$  • 356 x 70 x 248

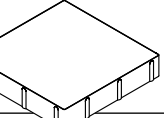
D   $14 \times 2\frac{3}{4} \times 14$  • 356 x 70 x 356

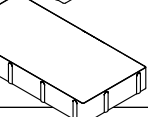
E   $18\frac{1}{4} \times 2\frac{3}{4} \times 9\frac{1}{4}$  • 464 x 70 x 248

SF/Layer	Layers/Pallet	SF/Pallet	Lbs./Pallet
10.77	8	86.16	2750

### Tranquility Pavers Layer Pattern

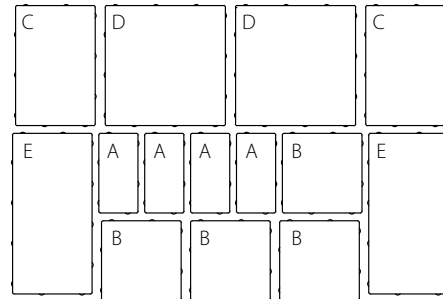

**Note:** Textured paver and patio stone surfaces require a buffer between the plate compactor and the paver surface to prevent scuffing. Refer to County Materials' Interlocking Concrete Paver or Slab Installation Guidelines, or contact County Materials for information.

### Tranquility Pavers Installation Patterns

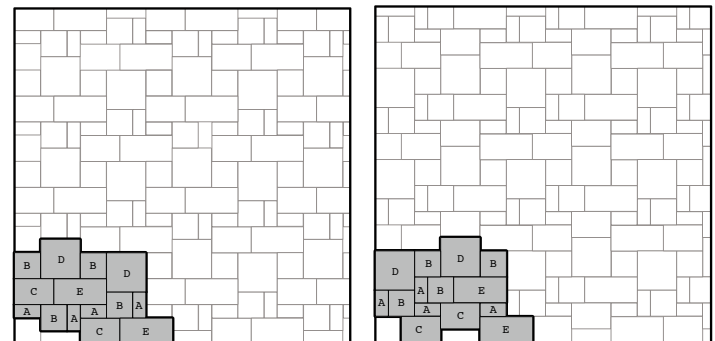

A, B, C, D & E Units  
A-7% B-23% C-19% D-27% E-24%

A, B, C, D & E Units  
A-7% B-23% C-19% D-27% E-24%





Tranquility Pavers – Serenity  
with border of Elements Paving Stones – Reflection,  
and Tribute Columns – Silverstone

## Color Options Tranquility Pavers

### Blended Colors

**NEW Color for 2019!**

Standard



Rustic



Haven

Oasis

Serenity

Timeless

Calm

Majestic

• Rustic Colors are manufactured On Demand.

*The color photos shown in this catalog were prepared with careful attention to accuracy. However, colors shown may vary from actual hues and should only be used as a guide. Refer to actual product samples for final color selection. Because concrete units are manufactured with high quality, naturally-mined aggregates and materials, variations in color or shading should be expected in products that are manufactured at different times and in units having different shapes. This color or shading variation is acceptable in the industry.*



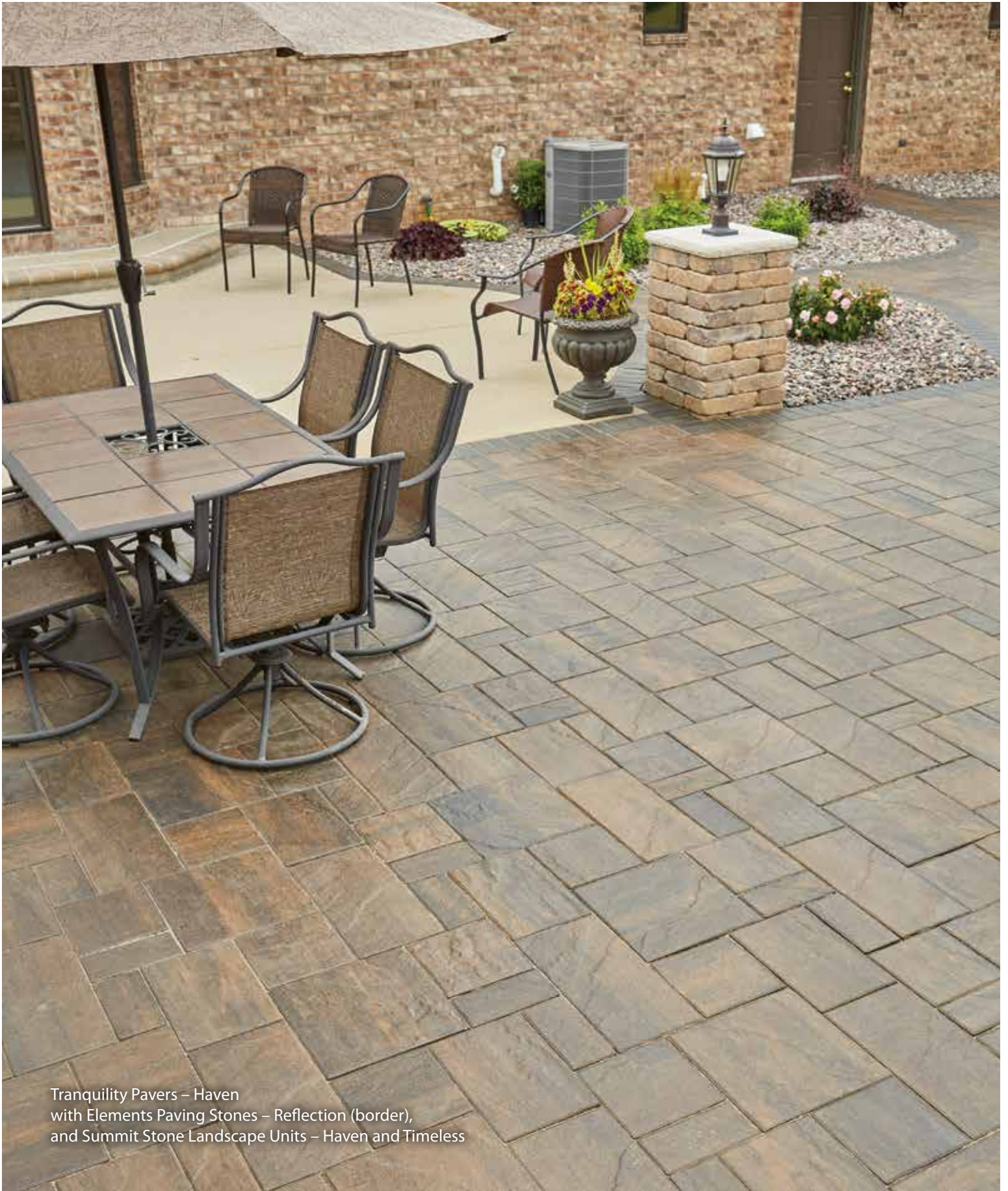

Tranquility Pavers – Haven  
with Elements Paving Stones – Reflection (border),  
and Summit Stone Landscape Units – Haven and Timeless





Tranquility Pavers – Serenity



Tranquility Pavers – Oasis  
with Elements border – Homecoming



Tranquility Pavers – Timeless  
with Tribute Retaining Wall System – Silvertone  
and Crest Bullnose Pavers – Timeless



## Face-mix Technology



- Focused Color Pigments
- Finest Aggregates
- Dense Concrete Mix

---

- Integrally Bonded
- Compressive Strength
- Larger Aggregates



Grand Milestone Pavers – Serenity  
with Summit Stone Landscape Units – Solace and Timeless



# Grand Milestone® Pavers

The scale and stunning color blends available in Grand Milestone Pavers will have you rethinking traditional concrete pavers.



GRAND  
**MILESTONE**  
PAVERS®





Grand Milestone Pavers – Serenity  
with Summit Stone Landscape Units – Solace and Timeless

**Grand Milestone® Pavers** make a simple yet bold statement with grand proportions. Their larger dimensions suit expansive driveway and courtyard applications and add vibrancy to quaint outdoor kitchens.

Use the three lengths of Grand Milestone Pavers on their own for a contemporary presence in residential and commercial applications.

## Sizes & Patterns **Grand Milestone Pavers**

D x H x L (Nominal Size)  
Inches • Millimeters

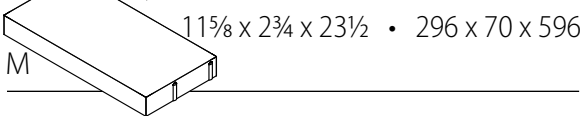
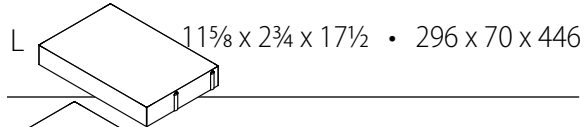
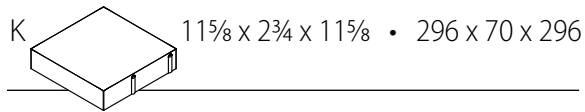

SF/Layer	Layers/Pallet	SF/Pallet	Lbs./Pallet
11.36	8	90.88	2970

Grand Milestone Pavers  
Layer Pattern

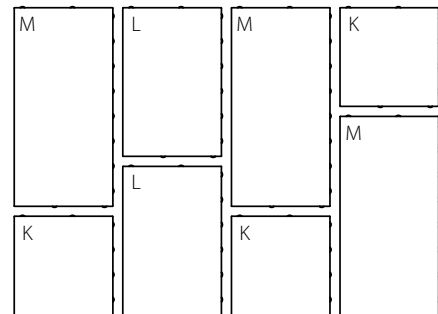

**Note:** Textured paver and patio stone surfaces require a buffer between the plate compactor and the paver surface to prevent scuffing. Refer to County Materials' Interlocking Concrete Paver or Slab Installation Guidelines, or contact County Materials for information.





Grand Milestone Pavers – Timeless  
with Elements Paving Stones – Vision (border)  
and Summit Stone Landscape Units – Haven

## Color Options **Grand Milestone Pavers**

**NEW Color for 2019!**

Blended Colors

Standard						
						Photo Not Available
Rustic	Haven	Oasis	Serenity	Timeless	Calm	Majestic

• Rustic Colors are manufactured On Demand.

*The color photos shown in this catalog were prepared with careful attention to accuracy. However, colors shown may vary from actual hues and should only be used as a guide. Refer to actual product samples for final color selection. Because concrete units are manufactured with high quality, naturally-mined aggregates and materials, variations in color or shading should be expected in products that are manufactured at different times and in units having different shapes. This color or shading variation is acceptable in the industry.*





Grand Milestone Pavers – Serenity



Grand Milestone Pavers – Serenity  
with Crest Bullnose Pavers – Vision,  
and H<sub>2</sub>O Pro Pavers – Serenity



Grand Milestone Pavers – Timeless  
with Summit Stone Landscape Units – Timeless



Grand Milestone Pavers – Timeless



## Face-mix Technology



- Focused Color Pigments
- Finest Aggregates
- Dense Concrete Mix

- Integrally Bonded
- Compressive Strength
- Larger Aggregates



Destination Pavers – Serenity, Haven and Timeless,  
Summit Stone Landscape Units – Haven,  
and County Stone – Cottage Brown (fireplace)



# Destination<sup>®</sup> Pavers

The organic appearance of Destination Pavers simulates flagstone aesthetics at its finest.

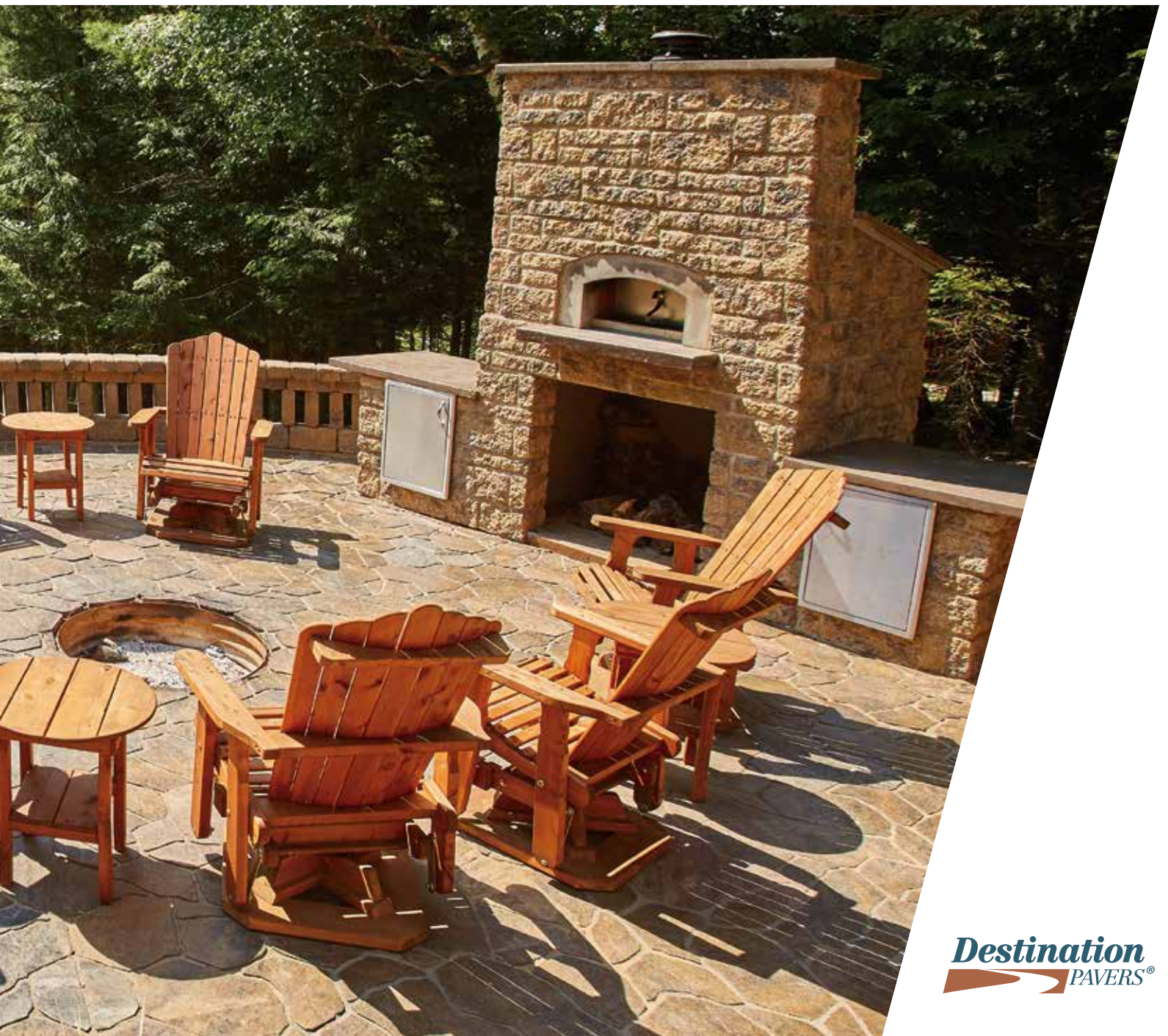

**Destination**  
PAVERS<sup>®</sup>







Destination Pavers – Serenity  
with Summit Stone Landscape Units – Haven

**Destination® Pavers** offer carefully crafted proportions and dimensions with nine sizes that fit together seamlessly and afford unlimited design freedom; you aren't restricted to follow a set pattern. Its tailored versatility also allows for simple combinations that blend well with other paver accents to become the quintessential focal point of any property.

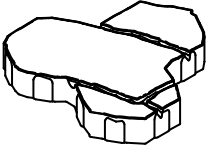
## Sizes Destination Pavers

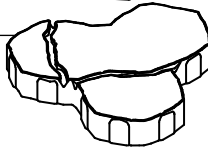
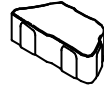
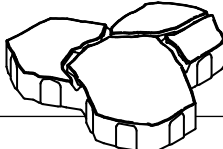
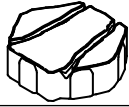
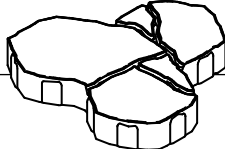
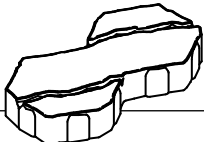
	D x H x L (Nominal Size) Inches • Millimeters		D x H x L (Nominal Size) Inches • Millimeters
A 	3 1/8 H • 80H (D & L Vary)	F 	3 1/8 H • 80H (D & L Vary)
B 	3 1/8 H • 80H (D & L Vary)	G 	3 1/8 H • 80H (D & L Vary)
C 	3 1/8 H • 80H (D & L Vary)	H 	3 1/8 H • 80H (D & L Vary)
D 	3 1/8 H • 80H (D & L Vary)	I 	3 1/8 H • 80H (D & L Vary)
E 	3 1/8 H • 80H (D & L Vary)		

SF/Layer	Layers/Pallet	SF/Pallet	Lbs./Pallet
11.11	8	88.88	2970



# Layer & Installation Patterns **Destination Pavers**

Destination Pavers Layer Pattern

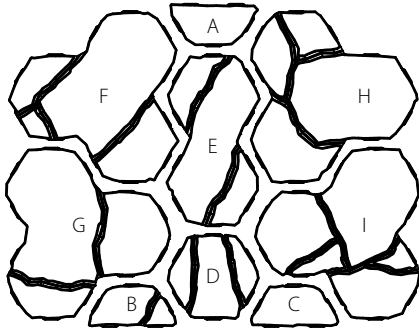

**Note:** Textured paver and patio stone surfaces require a buffer between the plate compactor and the paver surface to prevent scuffing. Refer to County Materials' Interlocking Concrete Paver or Slab Installation Guidelines, or contact County Materials for information.

Destination Pavers Installation Patterns

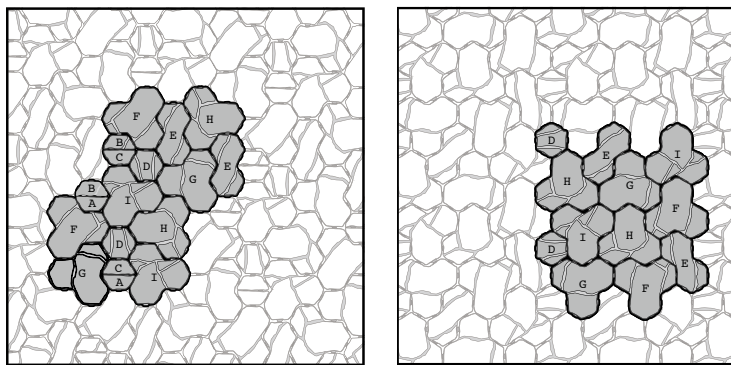

Destination Pavers Sidewalk Installation Pattern

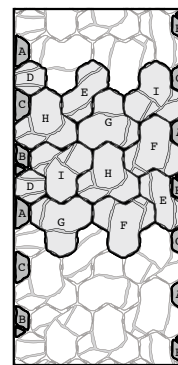

\* Approximately 57.5" in width

## Color Options **Destination Pavers**

Blended Colors

**NEW Color for 2019!**

Standard



Haven



Oasis



Serenity



Timeless

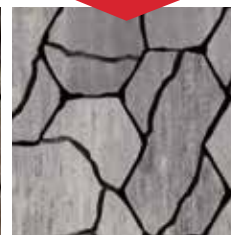

Majestic

The color photos shown in this catalog were prepared with careful attention to accuracy. However, colors shown may vary from actual hues and should only be used as a guide. Refer to actual product samples for final color selection. Because concrete units are manufactured with high quality, naturally-mined aggregates and materials, variations in color or shading should be expected in products that are manufactured at different times and in units having different shapes. This color or shading variation is acceptable in the industry.



Destination Pavers – Serenity





Destination Pavers – Haven  
with Elements Paving Stones – Reflection (border),  
Crest Bullnose Pavers – Vision  
and Summit Stone Landscape Units – Haven



Destination Pavers – Haven  
with County Block Retaining Wall System  
– Canyon Brown



Destination Pavers – Oasis  
with Elements Paving Stones – Homecoming (border)



Destination Pavers – Serenity, Haven and Timeless,  
and Summit Stone Landscape Units – Haven



Destination Pavers – Serenity  
with Summit Stone Landscape Units – Haven  
and Steel Fire Pit Insert





## Face-mix Technology



- Focused Color Pigments
- Finest Aggregates
- Dense Concrete Mix

- Integrally Bonded
- Compressive Strength
- Larger Aggregates





# Lifestyle® Pavers

## Grand Lifestyle® Pavers

Lifestyle and Grand Lifestyle Pavers offer the best of both worlds by marrying high strength concrete with the character and beauty of natural flagstone.



Grand Lifestyle Pavers – Haven  
and Summit Stone Landscape Units – Haven

*Lifestyle*  
Pavers®

*Grand Lifestyle*  
Pavers®



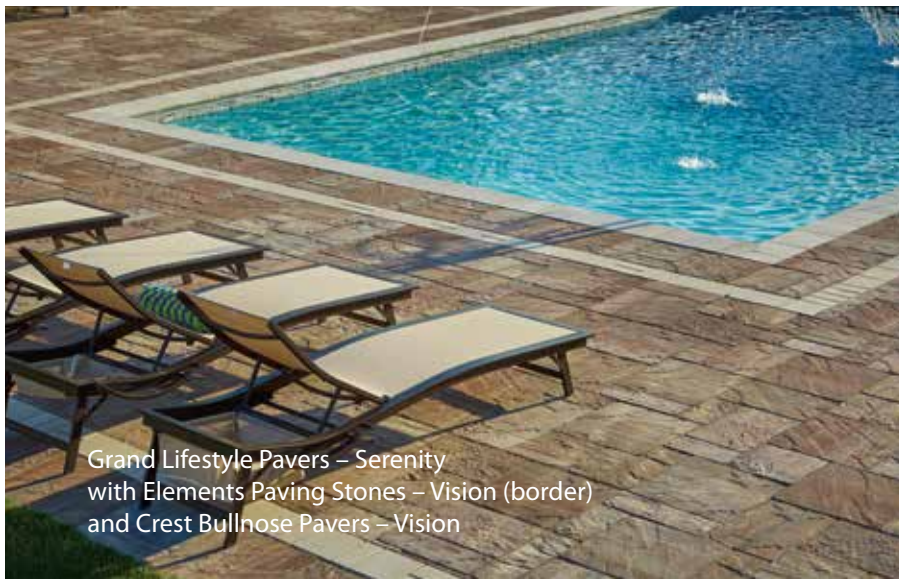

Grand Lifestyle Pavers – Serenity  
with Elements Paving Stones – Vision (border)  
and Crest Bullnose Pavers – Vision

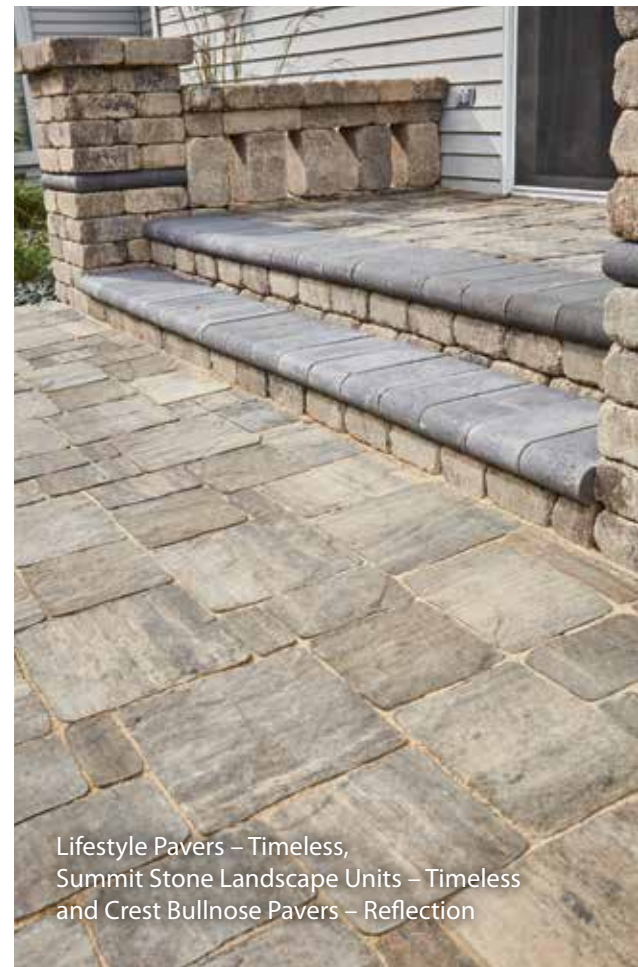

Lifestyle Pavers – Timeless,  
Summit Stone Landscape Units – Timeless  
and Crest Bullnose Pavers – Reflection

**Lifestyle® Pavers and Grand Lifestyle® Pavers** are crafted to deliver superior performance and lasting durability that withstands the tests of time. Their texture-rich surface and contoured sides are reminiscent of ancient European alleyways and corridors. Rotate the direction of Lifestyle and Grand Lifestyle Pavers during installation to create inviting, natural looking spaces.

## Sizes Lifestyle Pavers and Grand Lifestyle Pavers

### Lifestyle Pavers

D x H x L (Nominal Size)  
Inches • Millimeters

- A   $5\frac{15}{16} \times 2\frac{3}{4} \times 2\frac{15}{16}$  • 153 x 70 x 76

---

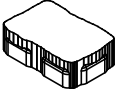
- B   $5\frac{15}{16} \times 2\frac{3}{4} \times \frac{7}{8}$  • 153 x 70 x 228

---

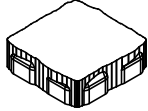
- C   $\frac{7}{8} \times 2\frac{3}{4} \times \frac{7}{8}$  • 228 x 70 x 228

---

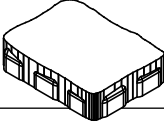
- D   $\frac{7}{8} \times 2\frac{3}{4} \times 1\frac{11}{16}$  • 228 x 70 x 307

---

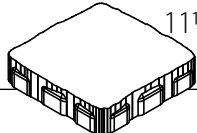
- E   $1\frac{11}{16} \times 2\frac{3}{4} \times 1\frac{11}{16}$  • 307 x 70 x 307

### Grand Lifestyle Pavers

D x H x L (Nominal Size)  
Inches • Millimeters

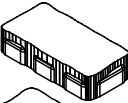
- F   $5\frac{15}{16} \times 2\frac{3}{4} \times 1\frac{11}{16}$  • 153 x 70 x 307

---

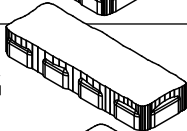
- G   $5\frac{15}{16} \times 2\frac{3}{4} \times 1\frac{7}{16}$  • 153 x 70 x 461

---

- H   $1\frac{11}{16} \times 2\frac{3}{4} \times 1\frac{11}{16}$  • 307 x 70 x 307

---

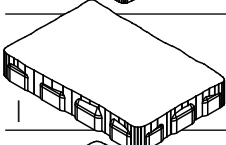
- I   $1\frac{11}{16} \times 2\frac{3}{4} \times 1\frac{7}{16}$  • 307 x 70 x 461

---

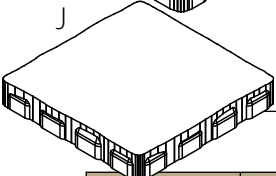
- J   $1\frac{7}{16} \times 2\frac{3}{4} \times 1\frac{7}{16}$  • 461 x 70 x 461

SF/Layer	Layers/Pallet	SF/Pallet	Lbs./Pallet
11	8	88	2760

SF/Layer	Layers/Pallet	SF/Pallet	Lbs./Pallet
12.33	8	98.64	3145



# Patterns Lifestyle Pavers and Grand Lifestyle Pavers

Lifestyle Pavers Layer Pattern

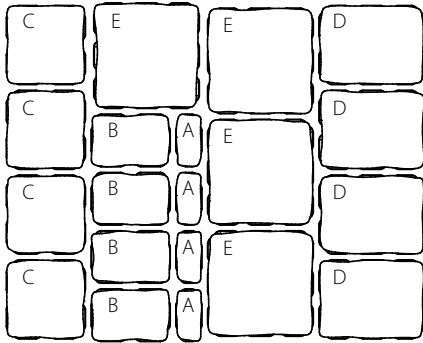

Grand Lifestyle Pavers Layer Pattern

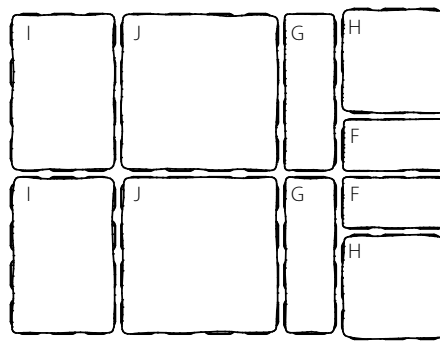

**Note:** Textured paver and patio stone surfaces require a buffer between the plate compactor and the paver surface to prevent scuffing. Refer to County Materials' Interlocking Concrete Paver or Slab Installation Guidelines, or contact County Materials for information.

Lifestyle Pavers Installation Patterns

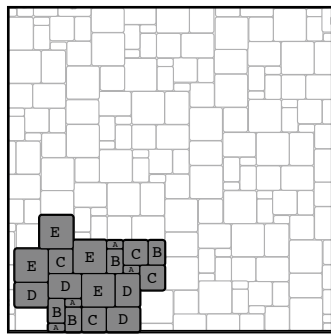

A, B, C, D & E Units  
Random

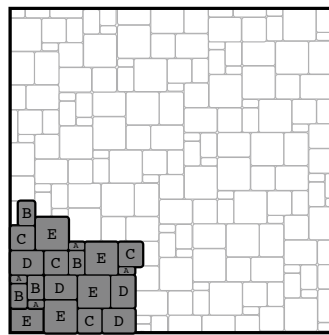

A, B, C, D & E Units  
Random

Grand Lifestyle Pavers Installation Pattern

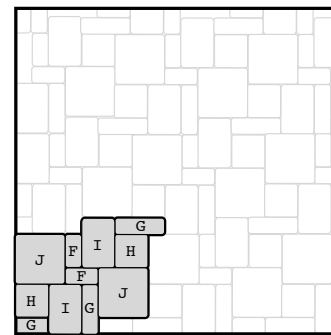

F, G, H, I & J Units  
Random

Lifestyle/Grand Lifestyle Pavers Installation Pattern

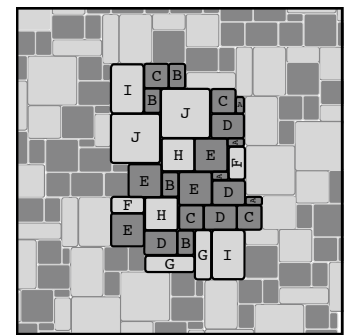

A, B, C, D, E, F, G, H, I & J Units  
Lifestyle Pavers®-50%  
Grand Lifestyle Pavers®-50%

## Color Options Lifestyle Pavers and Grand Lifestyle Pavers

Blended Colors

Standard



Haven



Oasis



Serenity



Timeless

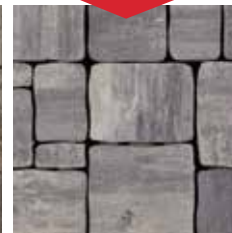

Majestic

**NEW Color for 2019!**

• Also available in Rustic Colors manufactured On Demand.

*The color photos shown in this catalog were prepared with careful attention to accuracy. However, colors shown may vary from actual hues and should only be used as a guide. Refer to actual product samples for final color selection. Because concrete units are manufactured with high quality, naturally-mined aggregates and materials, variations in color or shading should be expected in products that are manufactured at different times and in units having different shapes. This color or shading variation is acceptable in the industry.*





Grand Lifestyle Pavers – Majestic



Grand Lifestyle Pavers – Haven  
with Summit Stone Landscape Units – Haven



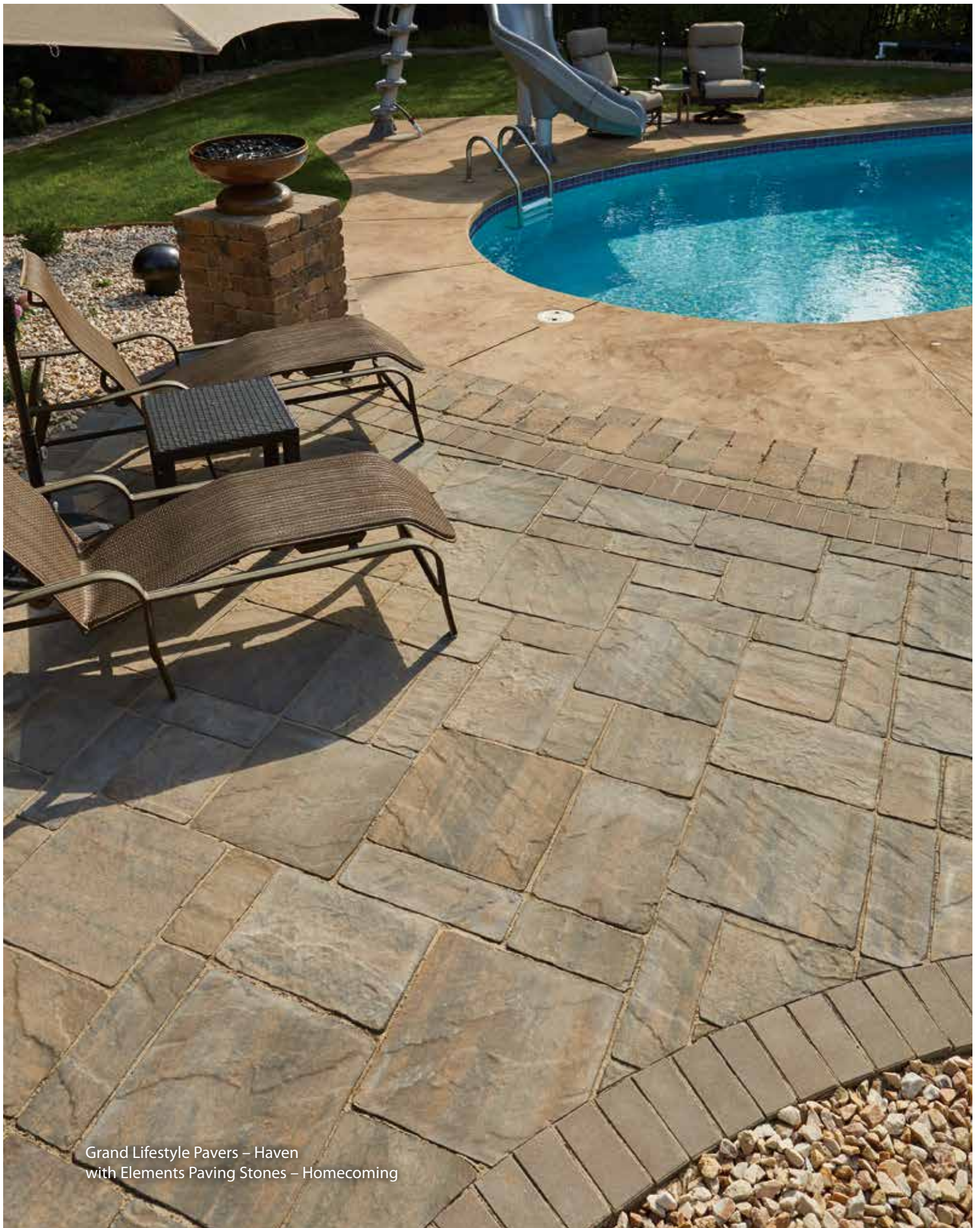

Grand Lifestyle Pavers – Haven  
with Elements Paving Stones – Homecoming



## Face-mix Technology



- Focused Color Pigments
- Finest Aggregates
- Dense Concrete Mix

- Integrally Bonded
- Compressive Strength
- Larger Aggregates

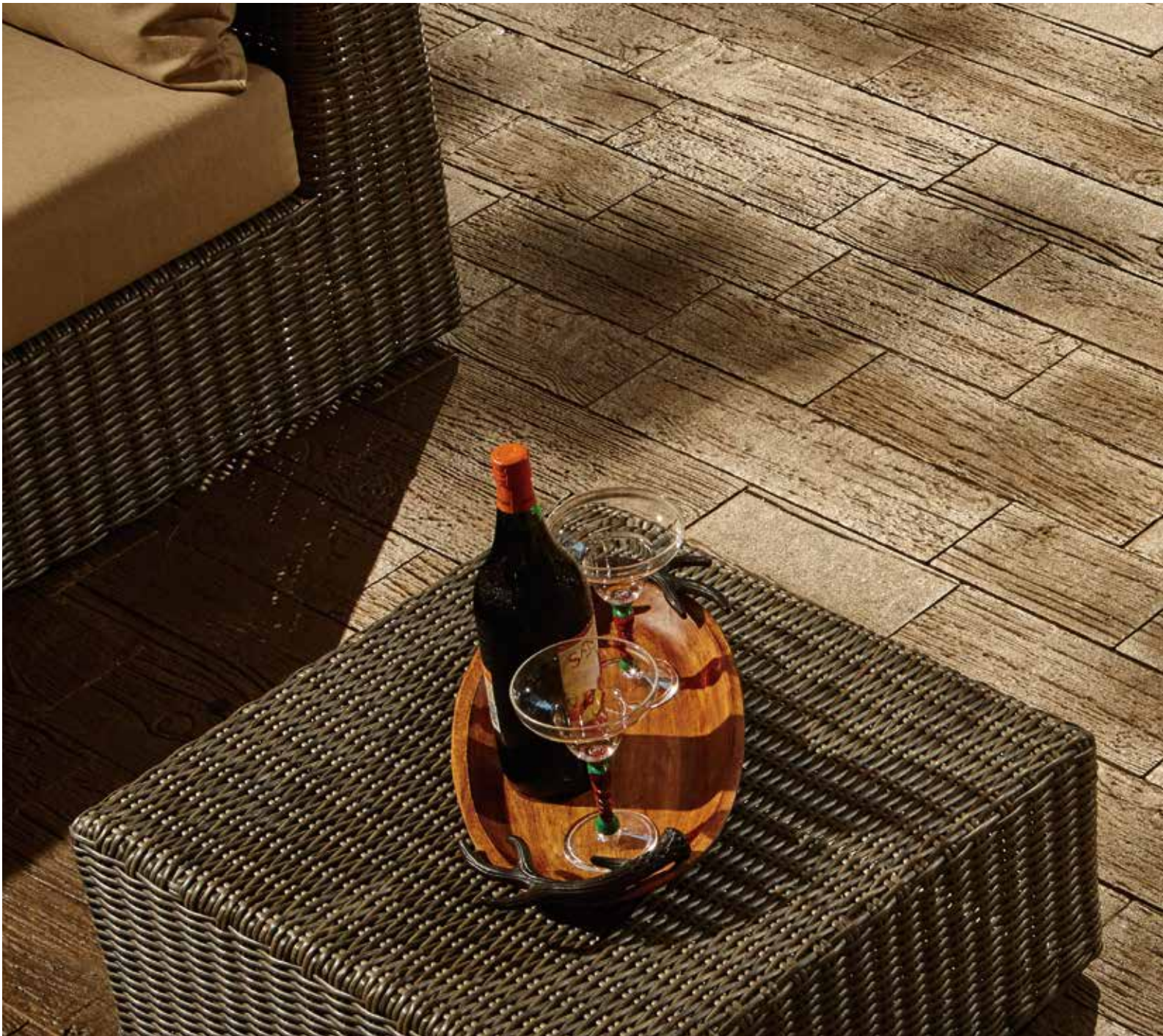



# Essence™ Wood Grain Plank Pavers

Essence Wood Grain Plank Pavers allow you to enjoy the deep rich textures of wood planks with the lasting durability and easy maintenance of concrete.



Essence Wood Grain Plank Pavers – Pride







Essence Wood Grain Plank Pavers – Pride

**Essence™ Wood Grain Plank Pavers** offer the unmatched durability of concrete with authentic looking grain and textures found in weathered wood, but without the maintenance requirements of typical wood products. Deep splits and detailed graining is featured on their surface. Five different plank lengths facilitate a linear laying pattern and create a dramatic effect.

## Sizes & Patterns **Essence Wood Grain Plank Pavers**

D x H x L (Nominal Size)  
Inches • Millimeters

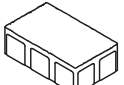
A   $5\frac{3}{4} \times 3\frac{1}{8} \times 9\frac{11}{16}$  • 146 x 80 x 246

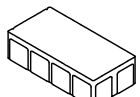
B   $5\frac{3}{4} \times 3\frac{1}{8} \times 11\frac{1}{8}$  • 146 x 80 x 296

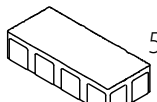
C   $5\frac{3}{4} \times 3\frac{1}{8} \times 13\frac{5}{8}$  • 146 x 80 x 346

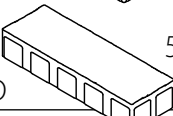
D   $5\frac{3}{4} \times 3\frac{1}{8} \times 17\frac{1}{2}$  • 146 x 80 x 446

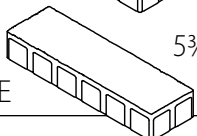
E   $5\frac{3}{4} \times 3\frac{1}{8} \times 19\frac{1}{2}$  • 146 x 80 x 496

SF/Layer	Layers/Pallet	SF/Pallet	Lbs./Pallet
10.74	8	85.92	3210

Essence Wood Grain Plank Pavers Layer Pattern

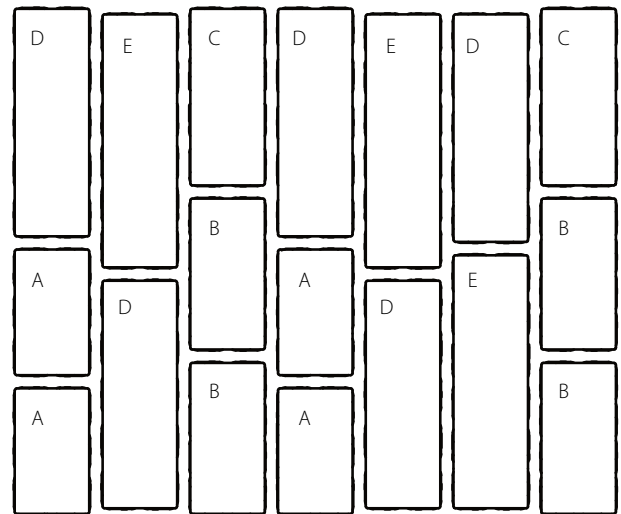

**Note:** Textured paver and patio stone surfaces require a buffer between the plate compactor and the paver surface to prevent scuffing. Refer to County Materials' Interlocking Concrete Paver or Slab Installation Guidelines, or contact County Materials for information.



# Color Options **Essence Wood Grain Plank Pavers**

## Blended Colors



*The color photos shown in this catalog were prepared with careful attention to accuracy. However, colors shown may vary from actual hues and should only be used as a guide. Refer to actual product samples for final color selection. Because concrete units are manufactured with high quality, naturally-mined aggregates and materials, variations in color or shading should be expected in products that are manufactured at different times and in units having different shapes. This color or shading variation is acceptable in the industry.*



Essence Wood Grain Plank Pavers – Pride



## Face-mix Technology



- Focused Color Pigments
  - Finest Aggregates
  - Dense Concrete Mix
- 
- Integrally Bonded
  - Compressive Strength
  - Larger Aggregates

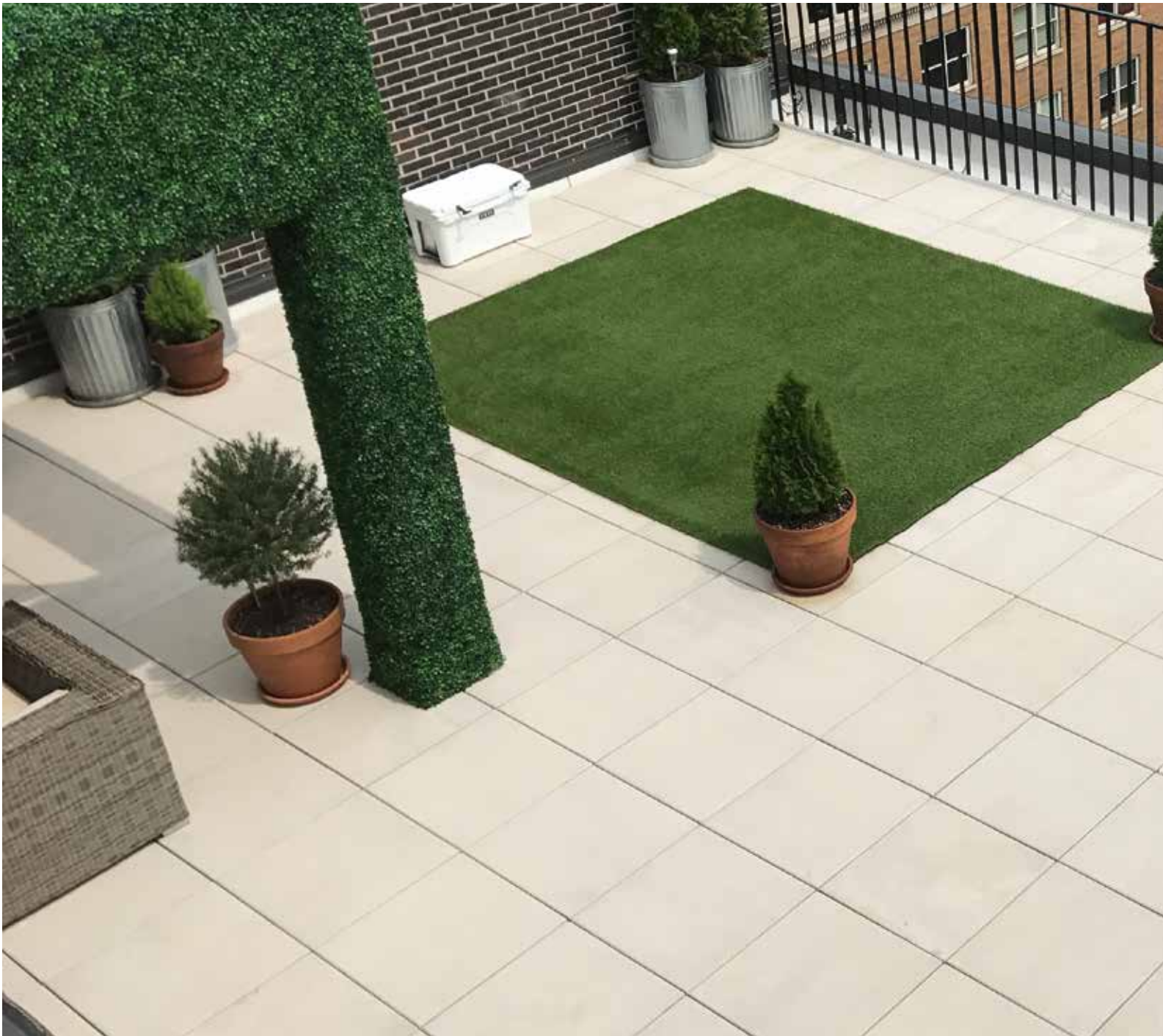



# Skylands™ Concrete Deck Pavers

Raise the status of your roof or patio area with Skylands Concrete Deck Pavers. Adjustable pedestals allow for easy installation and can turn pitched roofs into a flat usable surface.



Skylands Concrete Deck Pavers – Vision







Skylands Concrete Deck Pavers – Custom Color



Skylands Concrete Deck Pavers – Vision

**Skylands™ Concrete Deck Pavers** are lighter than the industry average; the 24" x 2" x 24" (nominal size) slabs are 24 lbs/sq. ft. Building owners are turning to concrete deck pavers for enhancing previously unusable spaces because of their many advantages:

- Prevents water damage with open joints
- Lengthens roof membrane lifespan by stopping harmful UV rays
- Seamlessly integrates with green roof features
- Roof components below slabs are easily accessible

## Sizes & Patterns Skylands Concrete Deck Pavers

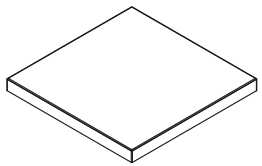

D x H x L (Nominal Size)  
Inches • Millimeters

23<sup>3</sup>/<sub>8</sub> x 2 x 23<sup>3</sup>/<sub>8</sub> • 594 x 51 x 594

SF/Unit	Units/SF	SF/Pallet	Units/Pallet	Lbs/Pallet
4	.25	92	23	2258

### For on grade applications

**Note:** Textured paver and patio stone surfaces require a buffer between the plate compactor and the paver surface to prevent scuffing. Refer to County Materials' Interlocking Concrete Paver or Slab Installation Guidelines, or contact County Materials for information.



Skylands Concrete Deck Pavers – Timeless



# Installation Layout Skylands Concrete Deck Pavers



Adjustable pedestals raise Skylands units to protect the roof below and enhance the space above.

## Skylands Concrete Deck Pavers Installation Layout

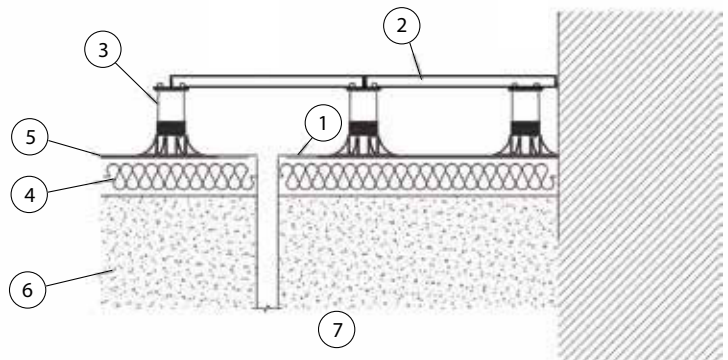
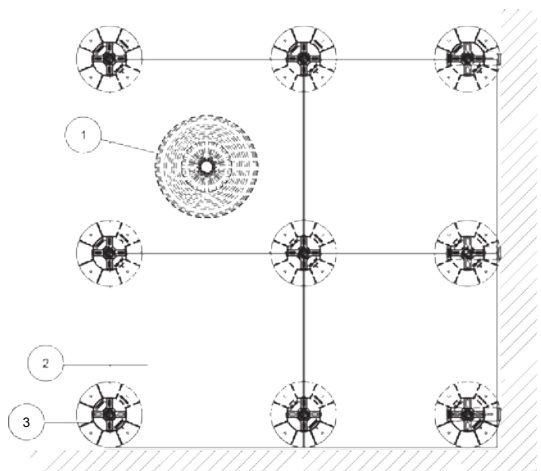

- 1 - Roof Drain
- 2 - Slab
- 3 - Adjustable Paving Support
- 4 - Waterproofing Membrane

- 5 - Thermal Isolation
- 6 - Concrete Slab
- 7 - Pipes



## Skylands Concrete Deck Pavers Installation Diagram

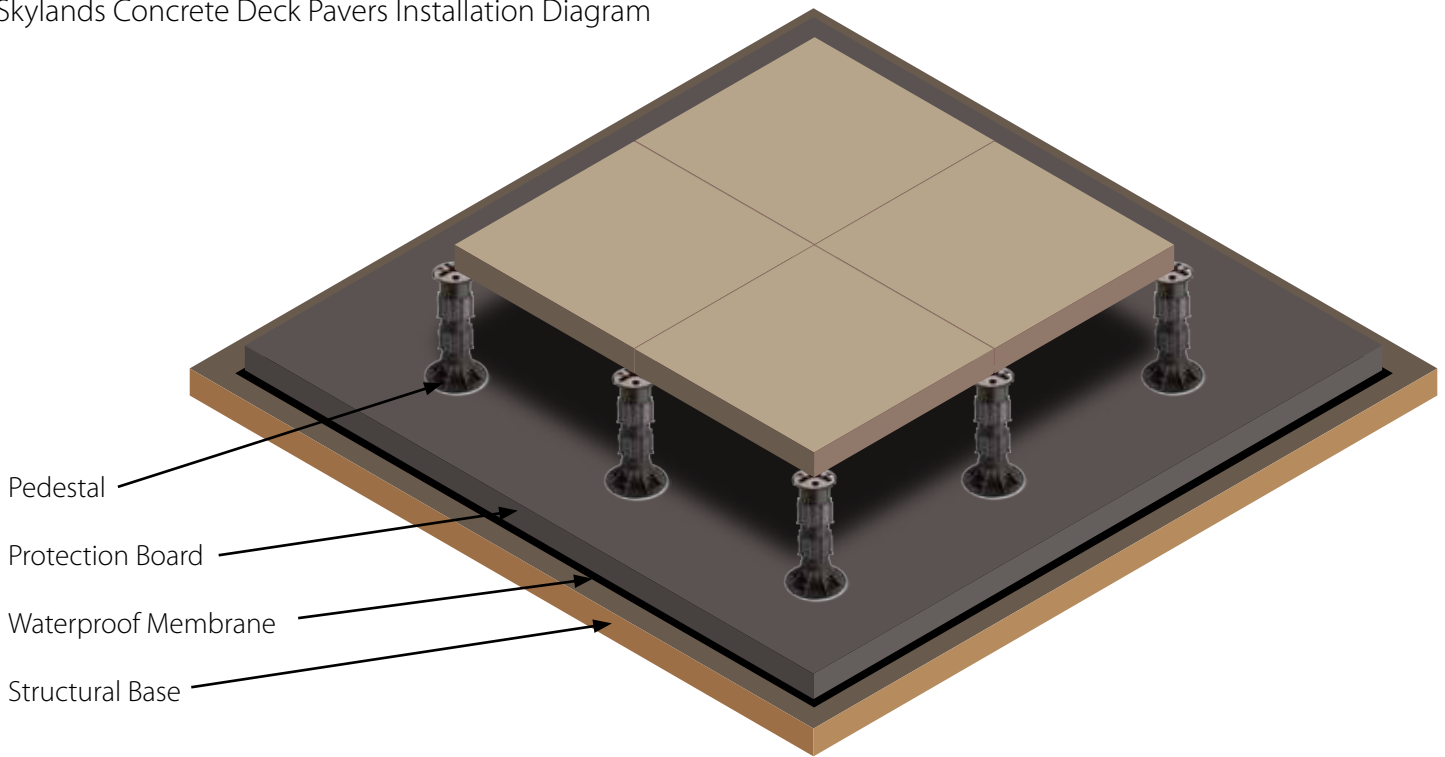

## Skylands Concrete Deck Pavers Installation Process

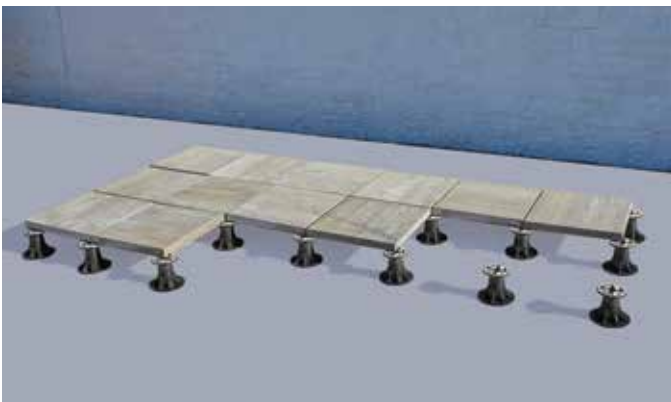

Determine pedestal height, layout and grid.  
Lay pavers 24" on center.



Use level during installation process for precision.



Easy adjustment with pavers in place.



Example of roof deck under construction.



# Color Options Skylands Concrete Deck Pavers

**NEW Color for 2019!**

## Blended Colors

Standard



Haven



Oasis



Serenity



Timeless



Majestic

## Solid Colors

Standard

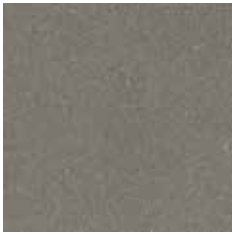

Dream

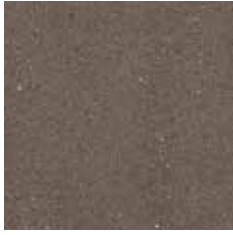

Homecoming



Reflection



Reunion



Vision



Traditions

Shotblast

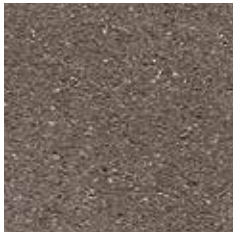

Photo  
Not  
Available

The color photos shown in this catalog were prepared with careful attention to accuracy. However, colors shown may vary from actual hues and should only be used as a guide. Refer to actual product samples for final color selection. Because concrete units are manufactured with high quality, naturally-mined aggregates and materials, variations in color or shading should be expected in products that are manufactured at different times and in units having different shapes. This color or shading variation is acceptable in the industry.



Skylands Concrete Deck Pavers – Timeless



*HNA Award Winner – 2018*



Crest Bullnose Pavers – Timeless,  
with Tribute Retaining Wall System – Canyon Brown,  
Destination Pavers – Timeless,  
and Elements Paving Stones – Timeless  
(Shown with Square Steel Fire Pit Insert)



# Crest™ Bullnose Pavers

Crest Bullnose Pavers are the absolute finishing touch to landscaping spaces. Manufactured with a smooth rounded front edge, they are a solution for enhancing any exposed edge.



CREST **BULLNOSE**  
pavers™





Crest Bullnose Pavers – Reflection

**Crest™ Bullnose Pavers** can be used to finish steps, pillars, walls, and pool copings; their applications are endless. Crest Bullnose Pavers also meet concrete paver specifications and can be used as accents in driveway and walkway applications. Crest Bullnose Pavers compliment County Materials' collection of pavers and wall products.

## Size Crest Bullnose Pavers

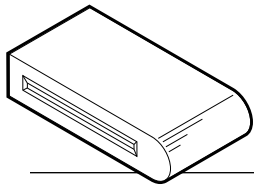

D x H x L (Nominal Size)  
Inches • Millimeters

6 x 2¾ x 12 • 152 x 70 x 305

SF/Unit	Units/SF	Lbs./Unit	Units/Cube	Lbs./Cube
.5	2	13.86	280	3931

**Note:** Textured paver and patio stone surfaces require a buffer between the plate compactor and the paver surface to prevent scuffing. Refer to County Materials' Interlocking Concrete Paver or Slab Installation Guidelines, or contact County Materials for information.

*The color photos shown in this catalog were prepared with careful attention to accuracy. However, colors shown may vary from actual hues and should only be used as a guide. Refer to actual product samples for final color selection. Because concrete units are manufactured with high quality, naturally-mined aggregates and materials, variations in color or shading should be expected in products that are manufactured at different times and in units having different shapes. This color or shading variation is acceptable in the industry.*

## Color Options Crest Bullnose Pavers

### Blended Colors

### Solid Colors

Standard

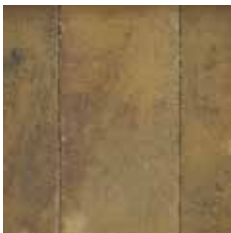

Barrel Tumbled



Haven

Oasis

Serenity

Timeless

Reflection

Vision





Crest Bullnose Pavers – Reflection



Crest Bullnose Pavers – Vision



Crest Bullnose Pavers – Haven



Crest Bullnose Pavers – Timeless



Crest Bullnose Pavers – Vision



## Face-mix Technology



- Focused Color Pigments
- Finest Aggregates
- Dense Concrete Mix

---

- Integrally Bonded
- Compressive Strength
- Larger Aggregates



H<sub>2</sub>O Pro® Pavers



Renewable™ Pavers



Harmony™ Permeable Pavers



# Permeable Interlocking Concrete Pavers

Permeable concrete pavers are the ideal solution for storm water management.

Permeable concrete pavers are designed to allow storm water to pass through paver joints directly into the ground, the use of permeable concrete pavers is proven and widely recognized by many municipalities, state agencies, shoreland and watershed districts for meeting EPA-mandated standards.

Permeable concrete paver systems help to improve water quality by capturing contaminants and suspended solids in storm water and filtering them through layers of aggregates. This also reduces the risk and severity of flooding, eliminates surface puddling and reduces the time for snow and ice removal by speeding up the melting process. Additionally, where space is at a premium, permeable concrete pavers

help to maximize land use on the total building site for residential and commercial applications, typically replacing traditional retention and detention ponds.

## Top 5 Reasons for Choosing Permeable Concrete Pavers

1. Increased profits: Gain a developable lot.
2. Reduction in risk associated with ponds (accidents, injuries, pests etc.).
3. Reduction in risk associated with freeze-thaw/standing water.
4. Increased curb appeal: Added aesthetic value.
5. Lower maintenance costs than traditional pavement.

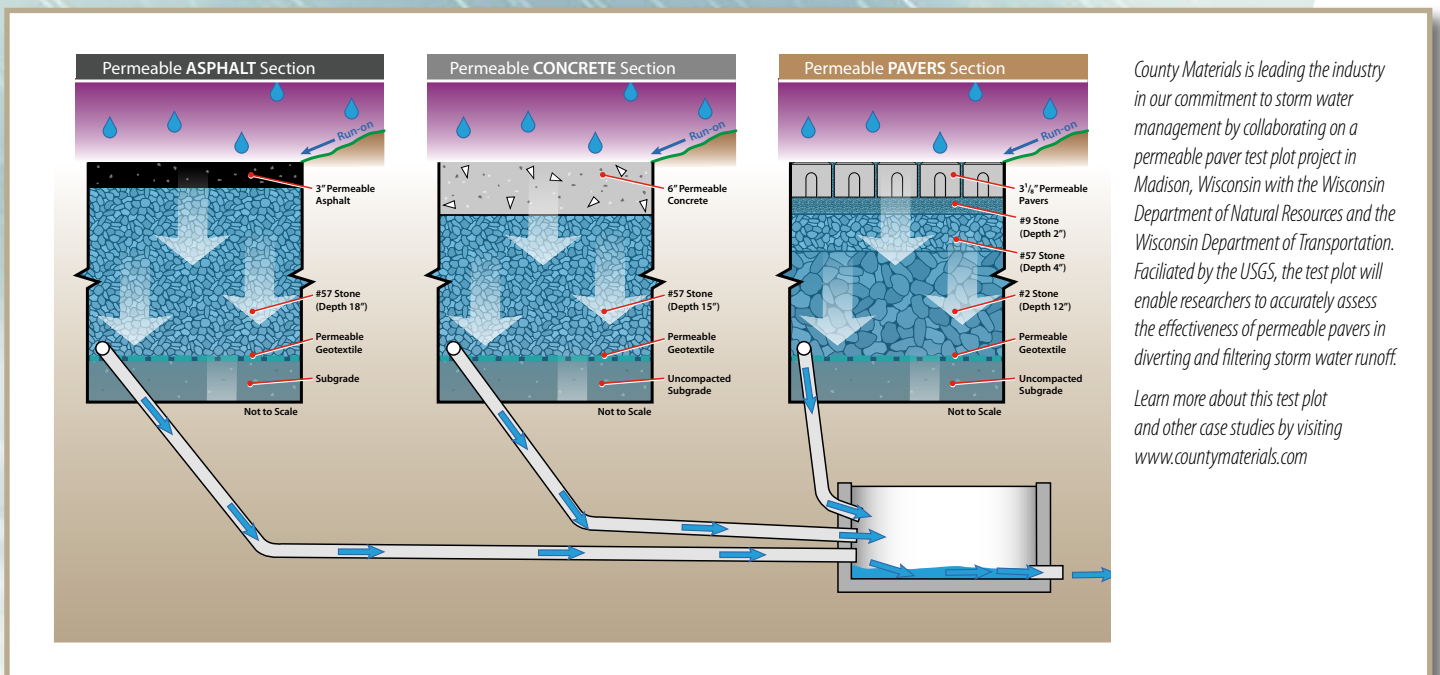



## Face-mix Technology



- Focused Color Pigments
- Finest Aggregates
- Dense Concrete Mix

---

- Integrally Bonded
- Compressive Strength
- Larger Aggregates



H<sub>2</sub>O Pro Pavers – Timeless



# H<sub>2</sub>O Pro<sup>®</sup> Pavers

## Permeable Paving Units

H<sub>2</sub>O Pro Pavers are manufactured in three dimensionally compatible sizes with hidden spacers.







H<sub>2</sub>O Pro Pavers – Reflection



H<sub>2</sub>O Pro Pavers – Haven

**H<sub>2</sub>O Pro® Pavers** accommodate high pedestrian areas and wheelchair traffic, making them a suitable option for entrances, walkways and retail courtyards. Their 3<sup>1</sup>/<sub>8</sub>" (80 mm) thickness also withstands heavy low speed vehicular loads.

## Sizes & Patterns H<sub>2</sub>O Pro Pavers

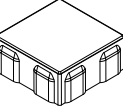
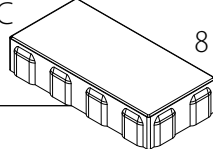
	D x H x L (Nominal Size) Inches • Millimeters	SF/Unit	Units/ SF	SF/ Layer	Layers/ Pallet	SF/ Pallet	Units/ Layer	Units/ Pallet	Lbs/ Pallet
A 	4 x 3 <sup>1</sup> / <sub>8</sub> x 8 • 102 x 80 x 203	.22	4.5	11	8	88	50	400	3085
B 	8 x 3 <sup>1</sup> / <sub>8</sub> x 8 • 203 x 80 x 203	.44	2.25	13.2	8	105.6	30	240	3695
C 	8 x 3 <sup>1</sup> / <sub>8</sub> x 16 • 203 x 80 x 406	.89	1.13	13.2	8	105.6	15	120	3820

- Installed joint dimensions = 10 mm (<sup>25</sup>/<sub>64</sub>" )
- Installed open area/layer = ±9.1% (depending on pattern)

### H<sub>2</sub>O Pro Pavers Permeable Layer Patterns

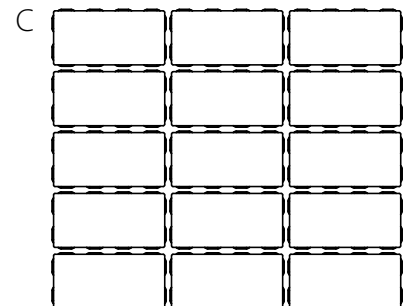
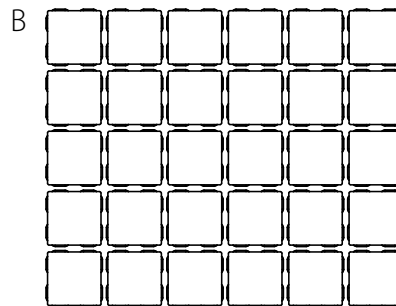
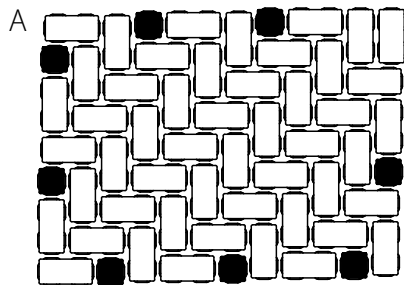

**Note:** The 4" x 8" size of H<sub>2</sub>O Pro Pavers are manufactured in a herringbone layer pattern that easily accommodates mechanical installation. Units can also be installed in many different patterns by hand.

**Note:** 4" x 4" fillers (see black squares in illustration for layer pattern "A") are used to keep the integrity of a layer when placed by a machine. They are provided at no charge and not sold separately. If 4" x 4" fillers are used in a pattern and more are needed, installers can cut 4" x 8" pavers in half and install where needed.



# Installation Patterns **H<sub>2</sub>O Pro Pavers**

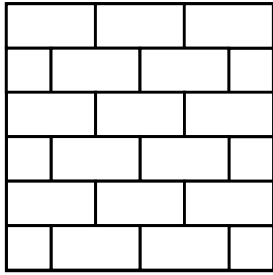

A or C Units Pattern #1

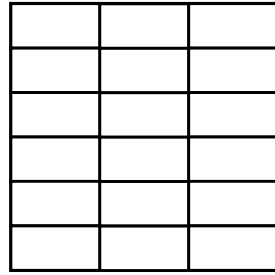

A or C Units Pattern #2

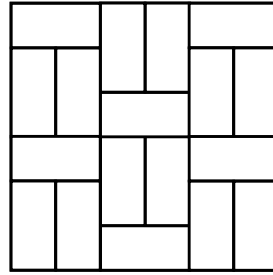

A or C Units Pattern #3

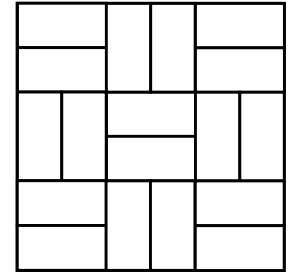

A or C Units Pattern #4

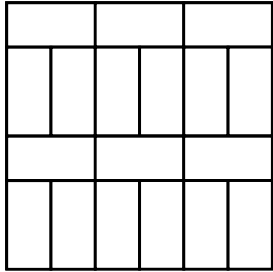

A or C Units Pattern #5

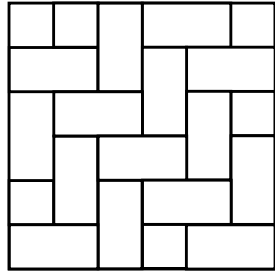

A or C Units Pattern #6

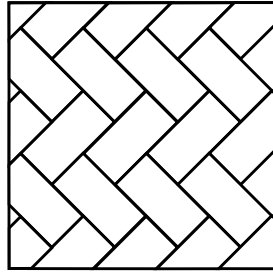

A or C Units Pattern #7

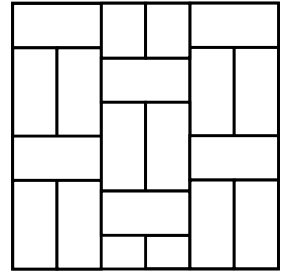

A or C Units Pattern #8

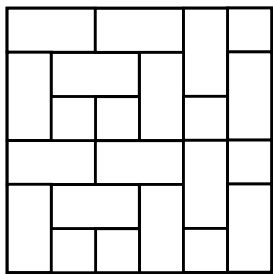

B or C Units Pattern #9

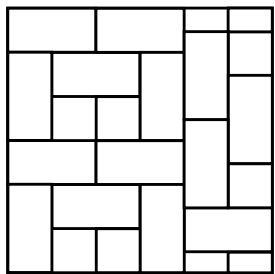

B or C Units Pattern #10

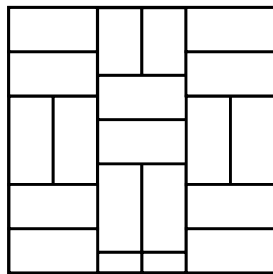

A or C Units Pattern #11

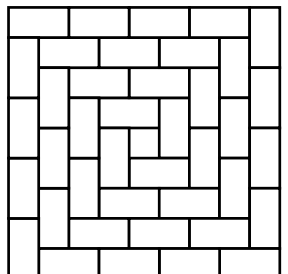

A or C Units Pattern #12

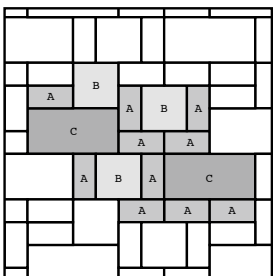

A, B & C Units #13  
A-42% B-25% C-33%

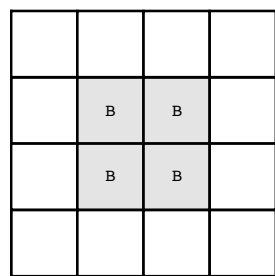

B Units #14

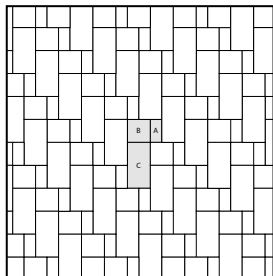

A, B & C Units Pattern #15  
A-17% B-29% C-57%

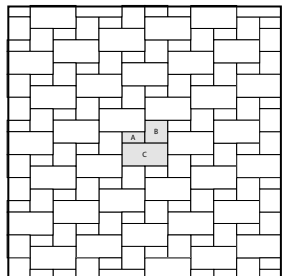

A, B & C Units Pattern #16  
A-14% B-29% C-57%

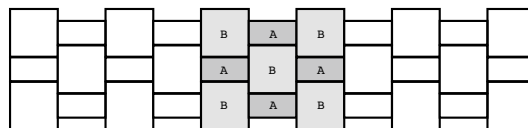

A & B Units #17  
A-29% B-71%

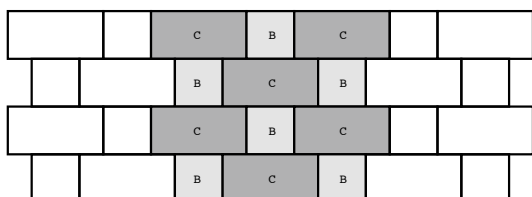

B & C Units #18  
B-33% C-67%

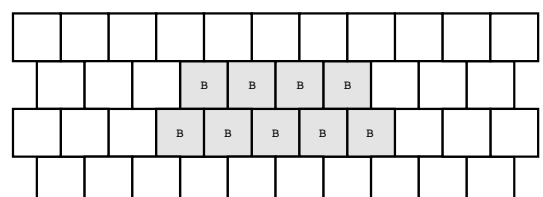













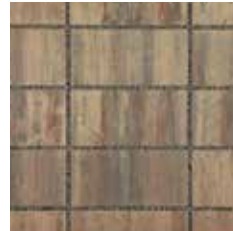
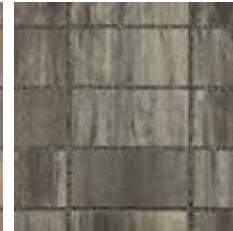
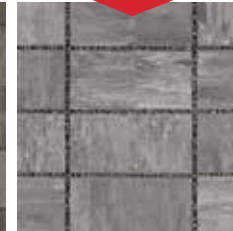

B Units #19



# Color Options **H<sub>2</sub>O Pro Pavers**

**NEW Color for 2019!**

## Blended Colors

Standard					
Rustic					Photo Not Available
Barrel Tumbled					Photo Not Available
Rustic Shotblast					Photo Not Available
	Haven	Oasis	Serenity	Timeless	Majestic

- Rustic, Barrel Tumbled and Rustic Shotblast Colors are manufactured On Demand.
- Also available in Rough Estate by Special Order.

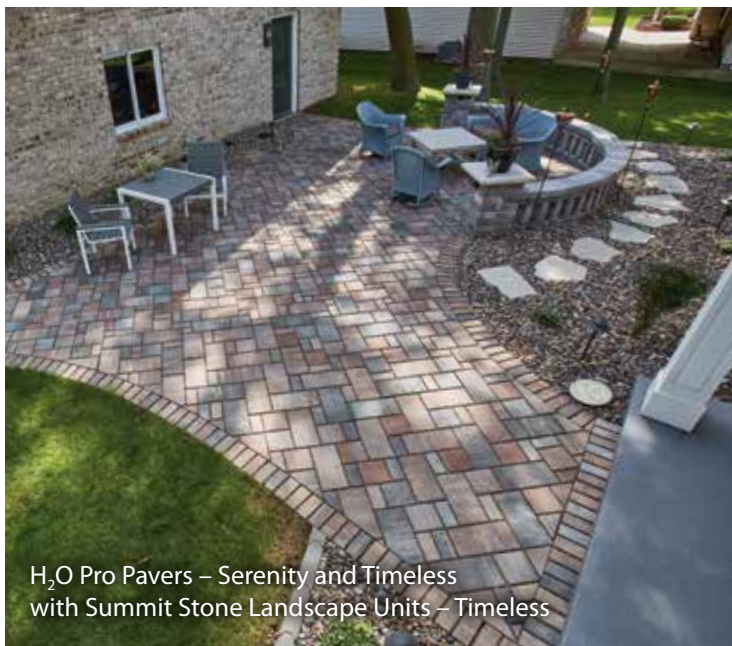

H<sub>2</sub>O Pro Pavers – Serenity and Timeless  
with Summit Stone Landscape Units – Timeless



H<sub>2</sub>O Pro Pavers – Reflection



Solid Colors

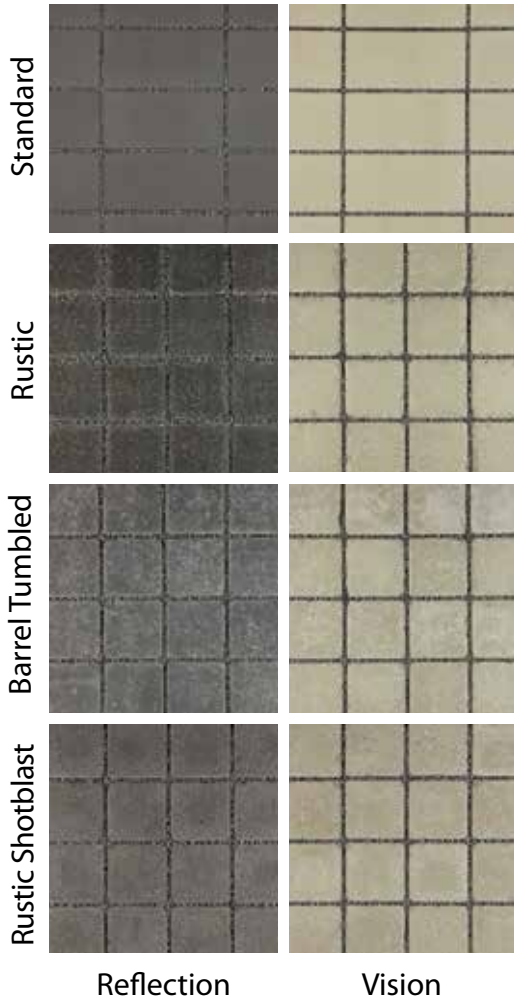

H<sub>2</sub>O Pro Pavers – Timeless, Haven and Vision



H<sub>2</sub>O Pro Pavers – Timeless

*The color photos shown in this catalog were prepared with careful attention to accuracy. However, colors shown may vary from actual hues and should only be used as a guide. Refer to actual product samples for final color selection. Because concrete units are manufactured with high quality, naturally-mined aggregates and materials, variations in color or shading should be expected in products that are manufactured at different times and in units having different shapes. This color or shading variation is acceptable in the industry.*



## Face-mix Technology



- Focused Color Pigments
  - Finest Aggregates
  - Dense Concrete Mix
- 
- Integrally Bonded
  - Compressive Strength
  - Larger Aggregates



Renewable Pavers – Reflection



# Renewable™ Pavers

## Permeable & Sandset Pavers

Renewable Pavers combine the integrity of an interlocking paver with the advantages of a permeable concrete paver system.







**Renewable™ Pavers'** larger joints accommodate drainage aggregates and units have hidden tabs. Renewable Pavers can also be manufactured as sandset units with smaller hidden tabs that hold jointing sand for non-permeable surfaces.

## Sizes & Patterns **Renewable Pavers**

D x H x L (Nominal Size)  
Inches • Millimeters

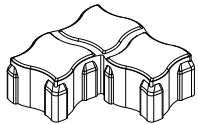

### Permeable

8<sup>5</sup>/<sub>8</sub> x 3<sup>1</sup>/<sub>8</sub> x 8<sup>5</sup>/<sub>8</sub> • 219 x 80 x 219

SF/ Unit	Units/ SF	SF/ Layer	Layers/ Pallet	SF/ Pallet	Units/ Layer	Units/ Pallet	Lbs/ Pallet
.4	2.5	10	8	80	25	200	2850

Renewable Pavers Permeable Layer Pattern

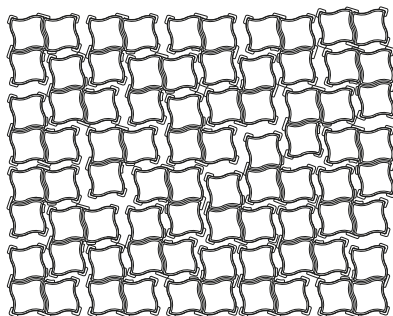

- Installed joint dimensions (Permeable) = 10 mm (<sup>25</sup>/<sub>64</sub>"
- Installed open area/layer = ±7.1%

D x H x L (Nominal Size)  
Inches • Millimeters

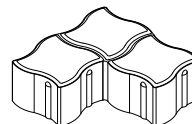

### Sandset

8<sup>5</sup>/<sub>8</sub> x 3<sup>1</sup>/<sub>8</sub> x 8<sup>5</sup>/<sub>8</sub> • 219 x 80 x 219

SF/ Unit	Units/ SF	SF/ Layer	Layers/ Pallet	SF/ Pallet	Units/ Layer	Units/ Pallet	Lbs/ Pallet
.4	2.5	10	8	80	25	200	3000

Renewable Pavers Sandset Layer Pattern

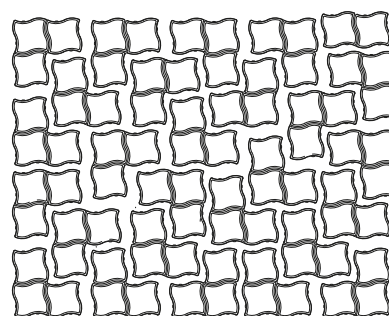

- Installed joint dimensions (non-permeable or sandset) = 2mm (1/16")

**Note:** Textured paver and patio stone surfaces require a buffer between the plate compactor and the paver surface to prevent scuffing. Refer to County Materials' Interlocking Concrete Paver or Slab Installation Guidelines, or contact County Materials for information.





Renewable Pavers – Homecoming and Vision

## Color Options Renewable Pavers

**NEW Color for 2019!**

### Blended Colors

Standard



Haven

Oasis

Serenity

Timeless

Calm

Majestic

### Solid Colors

Standard



Dream

Homecoming

Reflection

Reunion

Traditions

Vision

- All Renewable Pavers Standard Colors are manufactured by Special Order.
- Also available in Rough Estate by Special Order.

*The color photos shown in this catalog were prepared with careful attention to accuracy. However, colors shown may vary from actual hues and should only be used as a guide. Refer to actual product samples for final color selection. Because concrete units are manufactured with high quality, naturally-mined aggregates and materials, variations in color or shading should be expected in products that are manufactured at different times and in units having different shapes. This color or shading variation is acceptable in the industry.*



## Face-mix Technology



- Focused Color Pigments
- Finest Aggregates
- Dense Concrete Mix

---

- Integrally Bonded
- Compressive Strength
- Larger Aggregates



*HNA Award Winner – 2018*



Harmony Permeable Pavers – Peace



# Harmony™ Permeable Pavers

Harmony Permeable Pavers are designed with maximum performance in mind.







Harmony Permeable Pavers – Peace

**Harmony™ Permeable Pavers** wider joint dimensions, made possible with a larger lug, allow more water to filter through and ensure that Harmony Pavers function as part of an effective storm water management system, even in the heaviest rain events.

## Sizes Harmony Permeable Pavers

D x H x L (Nominal Size)  
Inches • Millimeters

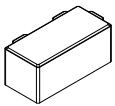
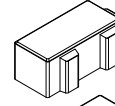
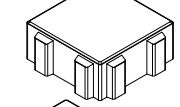
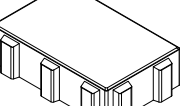
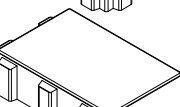
A1		4 x 3½ x 8 • 102 x 80 x 203
A2		4 x 3½ x 8 • 102 x 80 x 203
B		8 x 3½ x 8 • 203 x 80 x 203
C1		8 x 3½ x 12 • 203 x 80 x 305
C2		8 x 3½ x 12 • 203 x 80 x 305

SF/Layer	Layers/Pallet	SF/Pallet	Lbs./Pallet
11.51	8	92.08	3370

**Note:** Textured paver and patio stone surfaces require a buffer between the plate compactor and the paver surface to prevent scuffing. Refer to County Materials' Interlocking Concrete Paver or Slab Installation Guidelines, or contact County Materials for information.





# Layer & Installation Patterns **Harmony Permeable Pavers**

Harmony Permeable Pavers Layer Pattern

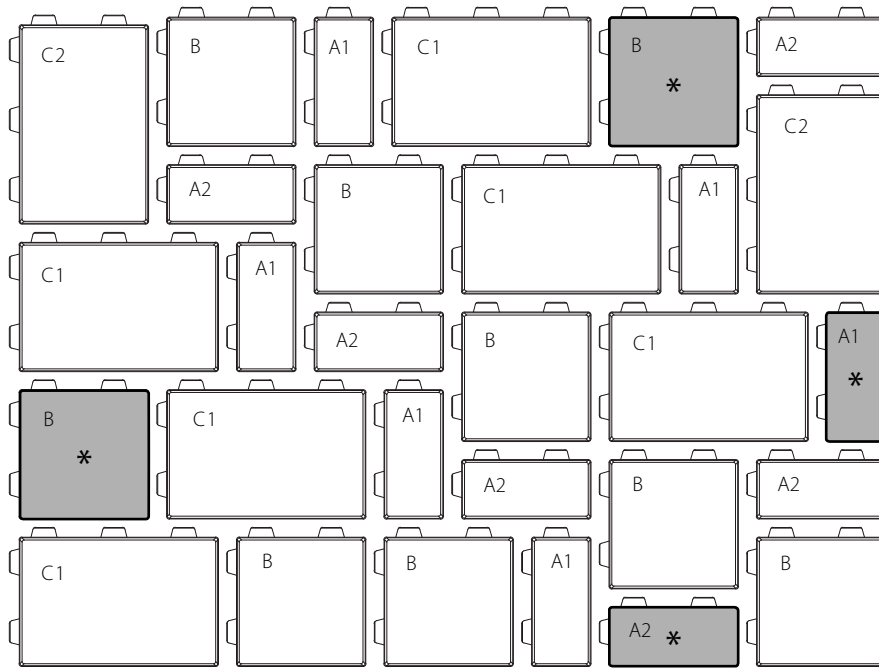

Harmony Permeable Pavers Installation Pattern

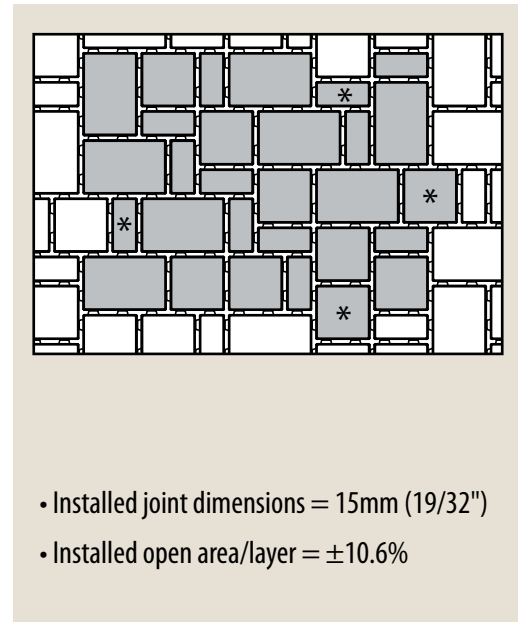

**Note:** In machine-laid applications, the shaded pavers shown above are designed to be interchangeable to allow for stitching of the pattern as indicated in the diagram at right. Harmony units are manufactured to create a three piece pattern, mechanically installed by pallet layer. Schematic above illustrates paver sizes/orientation on the layer.

## Color Options **Harmony Permeable Pavers**

### Blended Colors

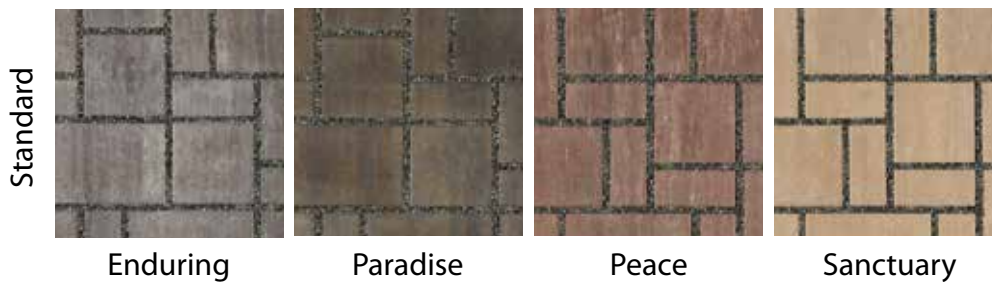

*The color photos shown in this catalog were prepared with careful attention to accuracy. However, colors shown may vary from actual hues and should only be used as a guide. Refer to actual product samples for final color selection. Because concrete units are manufactured with high quality, naturally-mined aggregates and materials, variations in color or shading should be expected in products that are manufactured at different times and in units having different shapes. This color or shading variation is acceptable in the industry.*

### Solid Colors

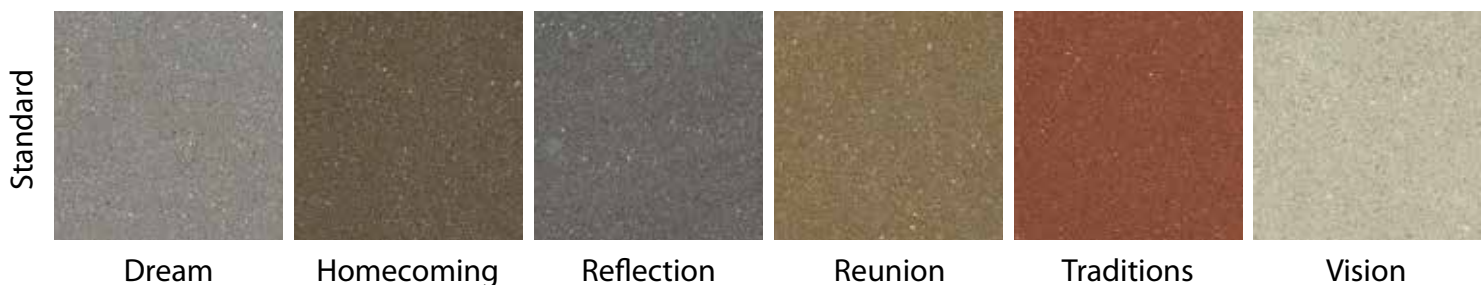

• All Harmony Permeable Pavers Standard Colors are manufactured by Special Order.





Elements Paving Stones – Vision with Haven (border)



# Pavers Borders & Accents

Contrasting paver styles and colors create unique borders and accents, and help to define separate areas or elevation changes near steps.

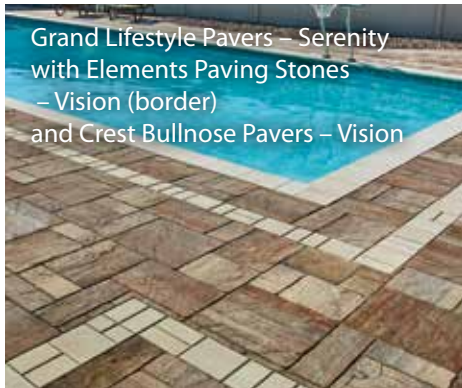

Grand Lifestyle Pavers – Serenity  
with Elements Paving Stones  
– Vision (border)  
and Crest Bullnose Pavers – Vision



Elements Paving Stones – Vision and  
Haven (border)



Tranquility Pavers – Haven  
(with border of Elements  
Paving Stones – Reflection)



Elements Paving Stones  
– Oasis (Rustic Shotblast)  
with Haven (Shotblast) border

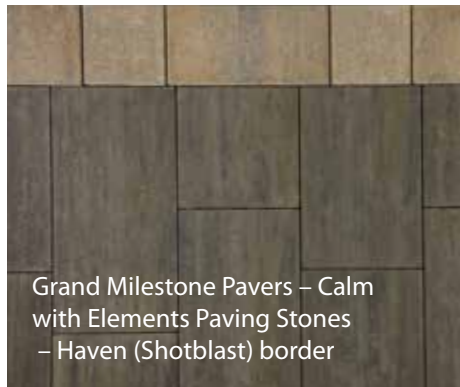

Grand Milestone Pavers – Calm  
with Elements Paving Stones  
– Haven (Shotblast) border



Elements Paving Stones – Haven  
and Vision with Oasis (border)



Destination Pavers – Serenity  
with Elements Paving Stones  
(Serenity) border



Elements Paving Stones – Serenity  
with Reflection (border)



Grand Milestone Pavers – Timeless  
with Elements Paving Stones  
– Vision (border)  
and Summit Stone  
Landscape Units – Haven



Tranquility Pavers  
– Timeless (with border  
of Elements Paving  
Stones – Reflection),  
Tribute Retaining Wall  
System – Silvertone  
and Crest Bullnose  
Pavers – Timeless





Bullet Edgers – Red  
(See page 83)



# Related Paver Items

## Patio Stones – Veranda & Courtyard

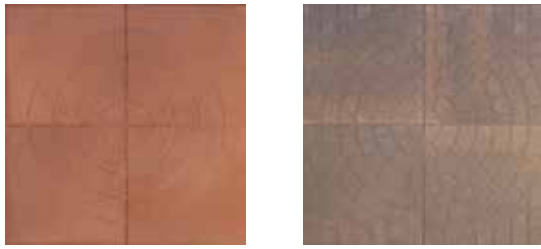

Veranda

Courtyard

- Veranda - Available in Gray and Red
- Courtyard - Available in Desert Sand, Iron River and Cedar Blend
- 4 stones make a circle pattern

D x H x L (Nominal Size)  
Inches • Millimeters  
17<sup>5</sup>/<sub>8</sub> x 2 x 17<sup>5</sup>/<sub>8</sub> • 457 x 51

SF/Unit	SF/Pallet	Units./SF	Units/Pallet	Lbs./Unit	Lbs./Pallet
2.25	162	.44	72	41	2997

## Patio Block

- Available in Gray, Brown, Red and Black



D x H x L (Nominal Size)  
Inches • Millimeters  
7<sup>5</sup>/<sub>8</sub> x 15<sup>5</sup>/<sub>8</sub> x 15<sup>3</sup>/<sub>8</sub> • 194 x 41 x 390

SF/Unit	SF/Layer	SF./Pallet	Layers/Pallet	Units./SF	Units/Layer	Units/Pallet	Lbs./Unit	Lbs./Pallet
.89	13.35	200.25	15	1.13	15	225	15	3420

## Bullet Edger

- Available in Gray, Red/Black, Red, Tan/Brown, Brown and Black



D x H x L (Nominal Size)  
Inches • Millimeters  
3<sup>5</sup>/<sub>8</sub> x 3 x 12<sup>1</sup>/<sub>4</sub> • 92 x 76 x 311

Units/Pallet	Lbs./Unit	Lbs./Pallet
240	10	2450

## Patio Stones – Smooth Round



Diameter x H (Nominal Size)  
Inches • Millimeters  
11<sup>5</sup>/<sub>8</sub> x 2 • 295 x 51  
Available in Gray and Red  
18 x 2 • 457 x 51  
Available in Gray and Brown

Size	Units/Pallet	Lbs./Unit	Lbs./Pallet
11 <sup>5</sup> / <sub>8</sub> x 2	216	17	3717
18 x 2	80	41	3243

## Patio Stones – Smooth Square

- Available in Gray, Red and Brown



D x H x L (Nominal Size)  
Inches • Millimeters  
11<sup>5</sup>/<sub>8</sub> x 2 x 11<sup>5</sup>/<sub>8</sub> • 295 x 51  
17<sup>5</sup>/<sub>8</sub> x 2 x 17<sup>5</sup>/<sub>8</sub> • 457 x 51

Size	SF/Unit	SF/Pallet	Units./SF	Units/Pallet	Lbs./Unit	Lbs./Pallet
11 <sup>5</sup> / <sub>8</sub> x 2 x 11 <sup>5</sup> / <sub>8</sub>	1.0	144	1.0	144	23	3357
17 <sup>5</sup> / <sub>8</sub> x 2 x 17 <sup>5</sup> / <sub>8</sub>	2.25	162	.44	72	46	3357

## Patio Stones – Brick Face

- Available in Gray, Red and Brown



D x H x L (Nominal Size)  
Inches • Millimeters  
17<sup>5</sup>/<sub>8</sub> x 2 x 17<sup>5</sup>/<sub>8</sub> • 457 x 51

Size	SF/Unit	SF/Pallet	Units./SF	Units/Pallet	Lbs./Unit	Lbs./Pallet
17 <sup>5</sup> / <sub>8</sub> x 2 x 17 <sup>5</sup> / <sub>8</sub>	2.25	162	.44	72	46	3357



## Grass Pavers

- Available in Gray
- Manufactured to meet ASTM C1319

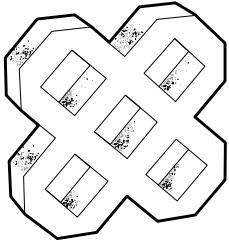

D x H x L (Nominal Size)  
Inches • Millimeters

16 x 3 $\frac{5}{8}$  x 16 • 406 x 92 x 406

SF/ Unit	Units/ SF	SF/ Layer	Layers/ Pallet	Units/ Layer	Units/ Pallet	Lbs/ Unit	Lbs/ Pallet
1.78	.56	10.67	10	6	60	47	2870



Grass Pavers Installation Pattern

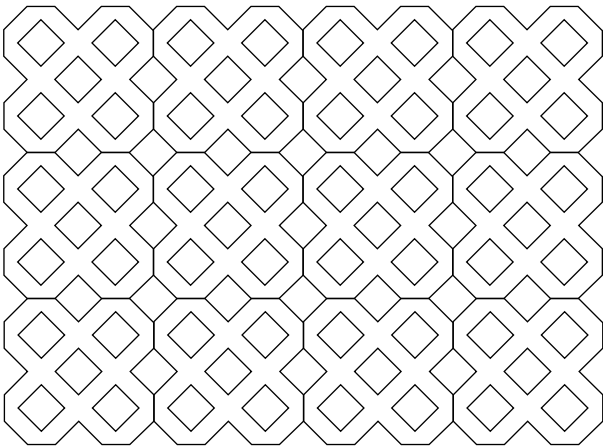

## Paver Sand

Product	Size/CF	Units/Pallet
SEK Polysweep	50 Lbs.	56
SEK Polysweep Wide Joint	50 Lbs.	56

## Edging

Product	Description
Landscape Spike	10"
SEK Snap Edge Paver Restraint	8' Long
SEK Low Profile Edge Paver Restraint	6' 8" Long
SEK Permeable Paver Restraint	8' Long
Edge Pro Lo-Pro Paver Restraint	7.5' Long
Edge Pro Lawn Edge	20' w/spikes
Edge Pro Stake	100/box
Edge Pro Connector	

## Paver Cleaners and Enhancers

Ask a County Materials representative for availability of paver cleaners and enhancers in your market.



## Air Conditioner Pads



D x H x L (Nominal Size)  
Inches • Millimeters

30 x 2 x 30 • 762 x 51 x 762  
36 x 2 x 24 • 914 x 51 x 610  
36 x 2 x 36 • 914 x 51 X 914

• Available in Gray

Size	Units/Pallet	Lbs/Unit	Lbs/Pallet
30 x 2 x 30	10	154	1585
36 x 2 x 24	10	143	1475
36 x 2 x 36	10	213	2175

## Parking Curbs

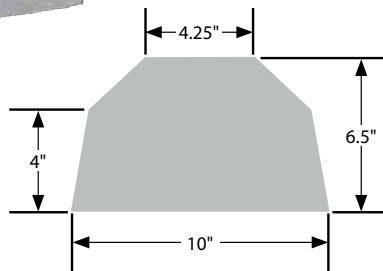
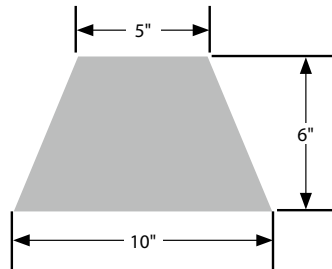
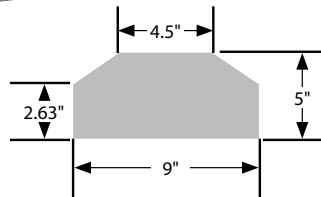

• Available in Gray  
• Nominal Size

Product	Size	Units/Pallet	Lbs/Unit	Lbs/Pallet
Parking Curb – No Notch	6'	15	274	4110
Parking Curb – Notched	6'	16	276	4416
Parking Curb	7'	16	320	5120
Pins	18"	N/A	N/A	N/A

## Pole Pads



Diameter x H (Nominal Size)  
Inches

Size	Units/Pallet	Lbs/Unit	Lbs/Pallet
12 x 4	108	34	3717
14 x 4	90	46	4185
16 x 6	30	106	3225
20 x 6	20	160	3245
22 x 6	20	195	3945

Size	Units/Pallet	Lbs/Unit	Lbs/Pallet
24 x 6	10	232	2365
24 x 8	8	310	2525
26 x 8	8	366	2973
30 x 8	4	480	1965

## Splash Block



• Available in Gray  
• Nominal Size

Size	Units/Pallet	Lbs/Unit	Lbs/Pallet
24"	32	40	1325
30"	32	45	1485

## Sign Post Bases



• Available in Gray  
• Nominal Size

Sign post bases are the ideal solution for municipal, commercial & residential needs:

- Street signs
- Handicap signs
- Commercial signage
- Parking signs
- Parking meters
- Metal fencing supports
- Tennis court nets and fencing
- Mailbox posts
- Driveway reflector stakes
- Birdhouse stakes (10' max ht.)
- Clothesline posts

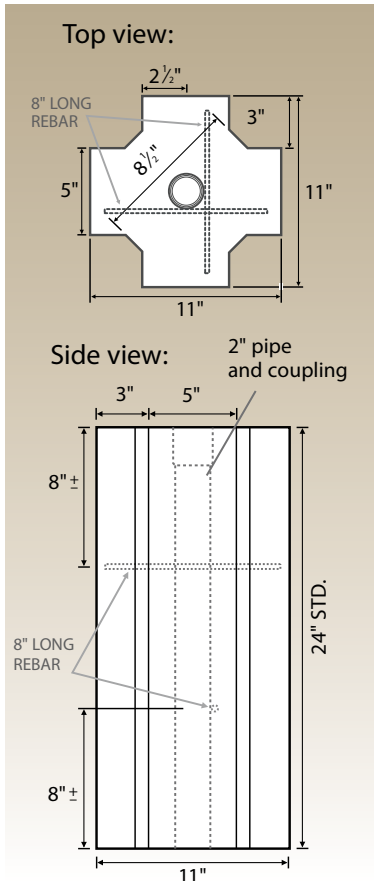



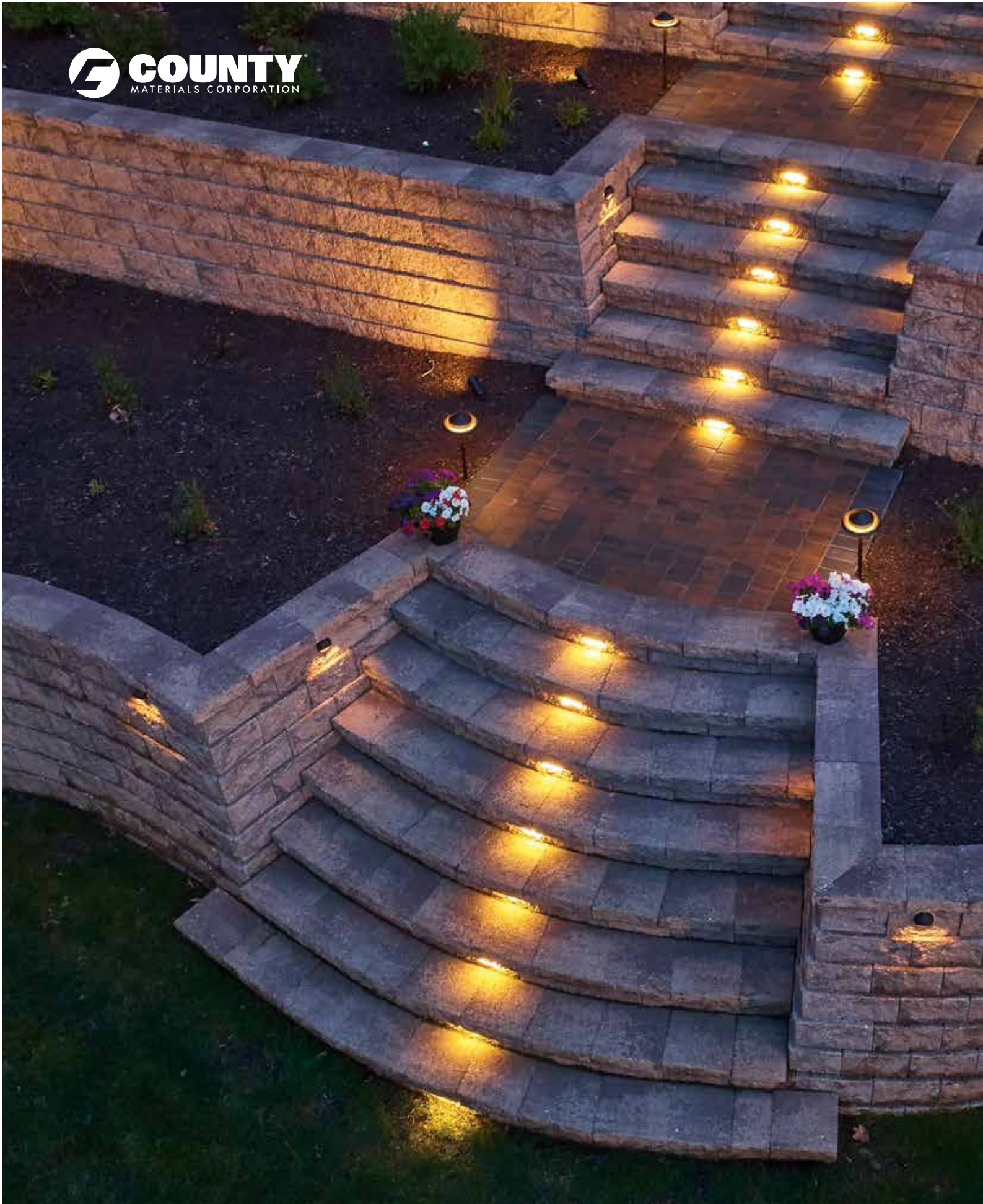





County Block Retaining Wall System – Swiss Mocha

# Retaining Walls, Garden Seat Walls & Step Units

- Rib Rock™ Landscape Block
- Tribute® Retaining Wall System
- County Block® Retaining Wall System
- Integrity™ Retaining Wall System
- Winston® Retaining Wall System
- Terrace Stone® Retaining Wall System
- Navaro® Retaining Wall System
- County Cub® Landscape Units
- Summit Stone® Landscape Units  
(See Outdoor Living Products section – Page 149)
- Landscape Step Unit
- Oversize Landscape Step Unit

## Related Retaining Wall Items:

- Landscape Fabric
- Adhesive
- Geogrid
- Wall Caps Splitface
- Wall Caps Rustic
- Bin Block

*The color photos shown in this catalog were prepared with careful attention to accuracy. However, colors shown may vary from actual hues and should only be used as a guide. Refer to actual product samples for final color selection. Because concrete units are manufactured with high quality, naturally-mined aggregates and materials, variations in color or shading should be expected in products that are manufactured at different times and in units having different shapes. This color or shading variation is acceptable in the industry.*



*WMA Award Winner – 2018*



Rib Rock Landscape Block – Gray (Rough)



# Rib Rock™ Landscape Block

Engineered for the most challenging applications, Rib Rock Landscape Block effortlessly builds oversized walls. Their large scale and natural aesthetics make a dramatic statement.





**Rib Rock™ Landscape Block** can easily construct walls from 6 feet to 20 feet high with additional site-specific engineering. Their size speeds up construction allowing for more square footage to be placed at one time, and their interlocking design allows for easy installation and enhanced security. Manufactured to hold back a lot of earth, Rib Rock units are the perfect solution for demanding projects that require lasting strength and enhanced durability.

## Shapes & Sizes Rib Rock Landscape Block

All Rib Rock units are available in both Dry Stack and Rough textures

### Rib Rock Rough Texture

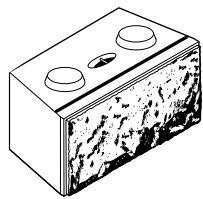

Tapered

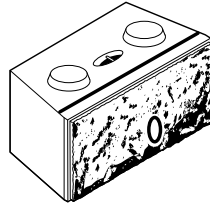

Tapered PVC

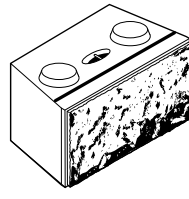

44" Short Offset Block

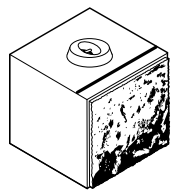

Half Block

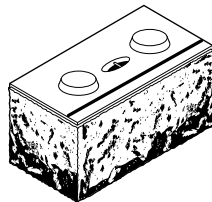

Rib Rock LH Corner

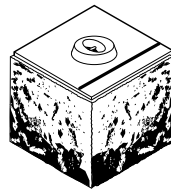

LH Half Corner

### Rib Rock Dry Stack Texture

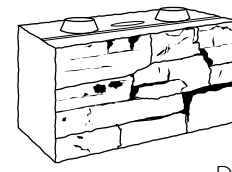

Dry Stack

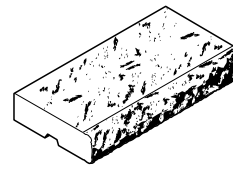
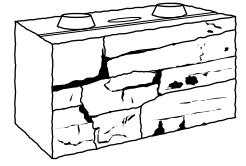

Rib Rock Cap

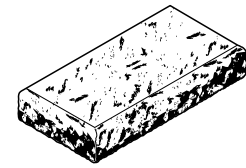

Rib Rock LH Corner Cap

Calculate the number of Rib Rock full and base block units needed: SF divided by 8.

Available in Rough or Dry Stack Textures	D x H x L (Nominal Size) Inches	SF/ Unit	Units/ Pallet	Lbs/ Unit	Lbs/ Pallet
Full Block 24" Flat w/6" PVC	23 x 24 x 48	7.6	2	2000	4045
44" Tapered	23 x 24 x 44	6.96	2	1850	3745
48" Tapered	23 x 24 x 48	7.6	2	2000	4045
52" Tapered	23 x 24 x 52	8.2	2	2800	5645
Base Block 28" Channel	27 x 24 x 48	7.6	2	2800	5645
Base Block 28" Smooth	27 x 24 x 48	7.6	2	2850	5745
1/2 Block	24 x 24 x 24	4	2	960	1965
Half Corner Block Left	24 x 24 x 24	4	2	1380	2805
Half Corner Block Right	24 x 24 x 24	4	2	1380	2805
Full Corner Block Left	27 1/2 x 24 x 52	8.2	2	2730	5505
Full Corner Block Right	27 1/2 x 24 x 52	8.2	2	2730	5505
Cap Block Straight	25 x 7 x 48	2.33	4	760	3085
Corner Cap Left	25 x 7 x 48	2.33	4	760	3085
Corner Cap Right	25 x 7 x 48	2.33	4	760	3085



Rib Rock Landscape Block – Gray (Dry Stack)

Contact Sales Representative for Two-sided Block/Cap Capability.



# Color Options Rib Rock Landscape Block

• Available in Gray as a Standard Color, or custom staining may be done onsite.



Rib Rock Landscape Block – Gray (Dry Stack)



Rib Rock Landscape Block – Gray (Rough)



Rib Rock Landscape Block – Gray (Rough)



Rib Rock Landscape Block – Gray (Rough)



Rib Rock Landscape Block – Gray (Rough)

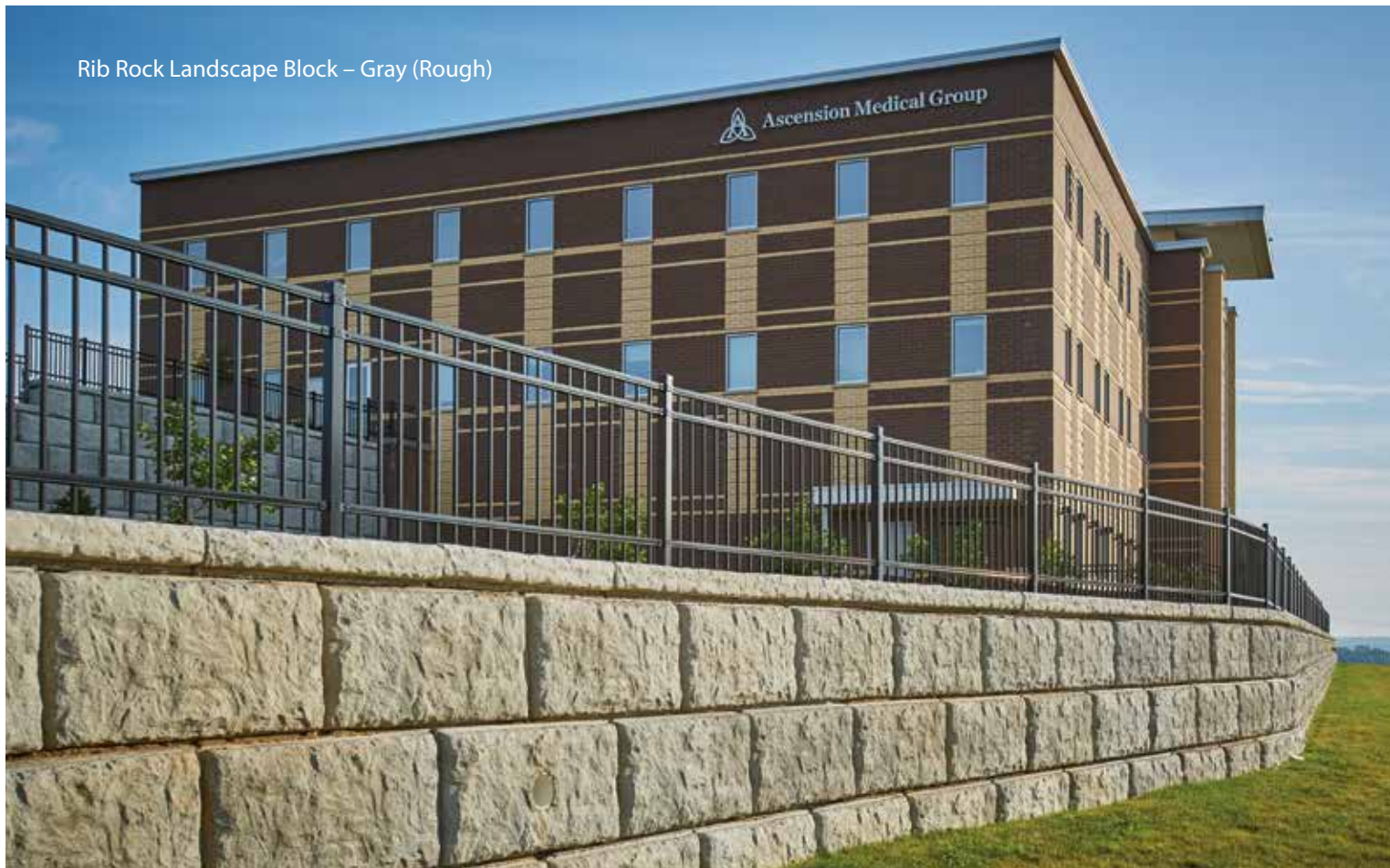





Rib Rock Landscape Block – Gray (Rough)



Rib Rock Landscape Block – Gray (Rough)



Tribute Retaining Wall System – Timeless (Rustic)





# Tribute<sup>®</sup> Retaining Wall System

The Tribute Retaining Wall System is engineered for ease of use and maximum versatility.







Tribute Retaining Wall System – Canyon Brown with Summit Stone Landscape Units – Haven

The **Tribute® Retaining Wall System** features solid block with multiple pin grooves on the top surface that allow for a combination of retaining and freestanding wall options, including vertical, stepped out or set back applications. Units can be efficiently split in half in the field to construct pillars or other wall accents, a perfect finishing touch to any project. With its countless design capabilities, Tribute Retaining Wall units are the premier choice for simple to ambitious landscape applications, including freestanding seat walls, steps, terraces and slope protection.

## Sizes Tribute Retaining Wall System

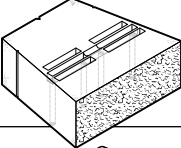
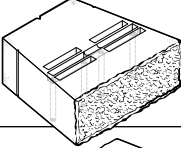
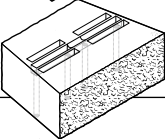
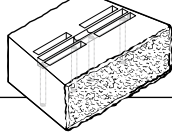
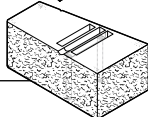
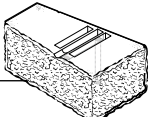
Splitface	Rustic	D x H x L (Nominal Size) Inches • Millimeters	SF/ Unit	Units/ Pallet	Lbs/ Unit	Lbs/ Pallet
		12 x 6 x 16 • 305 x 152 x 406	.67	36	73	2675
		10 x 6 x 16 • 254 x 152 x 406	.67	36	63	2313
		12 x 6 x 8 • 305 x 152 x 203	.33	72	37	2675

• Calculate the number of Tribute full units needed: SF x 1.5

**Note:** Retaining Wall Caps are available (Information is located on page 145).



# Color Options **Tribute Retaining Wall System**

Manufactured at our Appleton, WI location

## Blended Colors



## Solid Colors

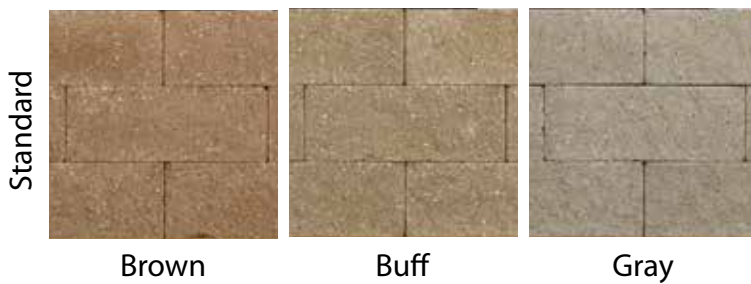

*The color photos shown in this catalog were prepared with careful attention to accuracy. However, colors shown may vary from actual hues and should only be used as a guide. Refer to actual product samples for final color selection. Because concrete units are manufactured with high quality, naturally-mined aggregates and materials, variations in color or shading should be expected in products that are manufactured at different times and in units having different shapes. This color or shading variation is acceptable in the industry.*

Manufactured at our Roberts, WI location

## Blended Colors



## Solid Colors



## Blended Rustic Colors



- October Oak is available as a Special Production order in some markets. Call for availability.
- Also available in Buff and Gray Solid Colors; and Gray-Rustic Solid Color.



# Wall Configurations **Tribute Retaining Wall System**



Tribute Retaining Wall – Silvertone



Tribute Retaining Wall – Silvertone (Rustic)

## **Tribute retaining walls with pins:**

Each Tribute unit has a unique three-position pin placement system. Two pins per unit secure Tribute block in place.

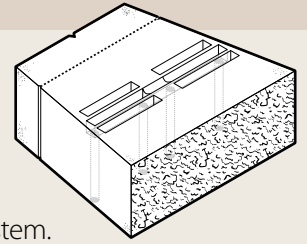

### • **Tribute Two-sided Vertical Face Seat Wall Installation**

It is recommended that all seat walls have the first course buried for embedment. Starting on the second and succeeding courses, position all Tribute units with the pinholes over the middle-receiving channel. This will lock the units in a vertical position. Seat walls should not exceed a height of 36".

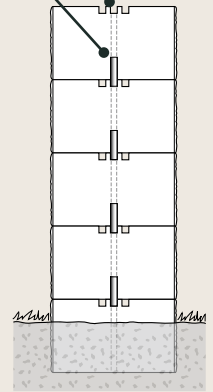

### • **Tribute Two-sided Recessed Face Seat Wall Installation**

Place every course on the opposite receiving channel than the previous. This will give your Tribute Retaining Wall System a three dimensional look.

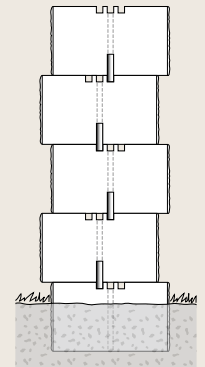

### • **Tribute Set Back Retaining Wall Installation**

Position pinholes of each successive Tribute unit over the rear-receiving channel on the lower unit. This placement will give your Tribute wall an approximate 7° set back.

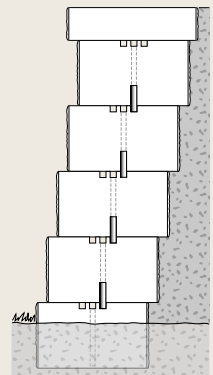



# Seat Walls and Columns Design **Tribute Retaining Wall System**

## Finished Ends and Corners on Tribute Two-sided Seat Wall Installations

To finish your free standing seat wall on each end, split 2" off the back of each unit at the indicated grooves for a two-sided split appearance on the front and back faces. Then split the unit in half (front to back) at the indicated center notch to achieve two half blocks with three split sides. At your desired seat wall starting point, place one half block with a split surface facing out (Figure 2). Next install full units side-by-side for the length of the seat wall. End the course by placing another half block with a split surface facing out.

**Second course:** Split another two sided Tribute unit in half as before. On one half block, measure and mark the width of one face at 2-7/8". On the other split face, measure and mark its width at 4 -7/8". Draw a line between each marked face and saw the unit along the appropriate angle to create a specially cut two-sided 1/4 return unit. Place one sawed 1/4 piece, split surface out, on the end of the first course to start the second course. Make sure the cut angle of this second course unit is opposite of the angle in the first course for proper bond. Use retaining wall adhesive to hold all end pieces securely in place. Continue laying standard units side-by-side, and install the other 1/4 return unit at the end of the seat wall following the same instructions.

Continue building successive courses by repeating instructions above, alternating each 1/4 return end unit and using adhesive for proper stability. When the seat wall is finished to the proper height, adhere caps for a finished effect.

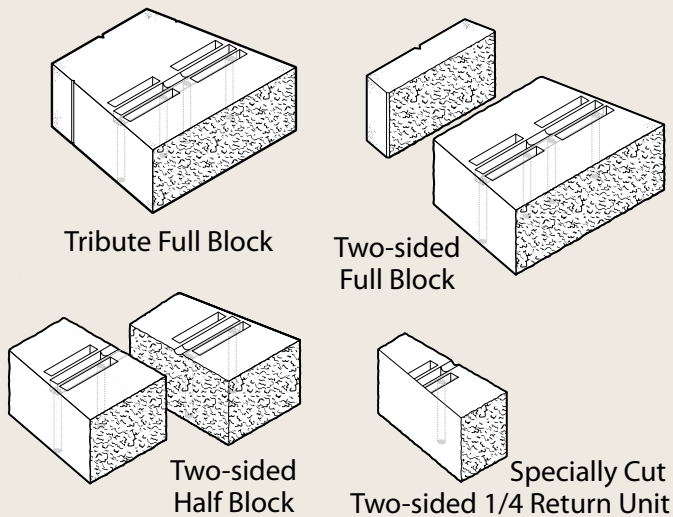
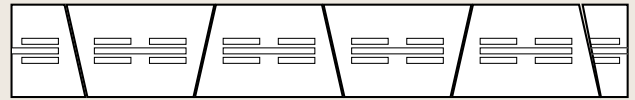
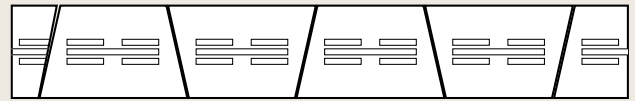

Figure 2 Tribute Two-sided Seat Wall



Courses 1,3,5...



Courses 2,4,6...

## Constructing Columns and Pillars with Tribute units:

Split Tribute units in half (as shown). Place four half units per course in alternating running bond pattern. Apply concrete adhesive between each course as you construct the pillar. The hollow area inside a pillar can accommodate electrical conduit for a light or a wood 4" x 4" post to support a trellis, light or garden gate.

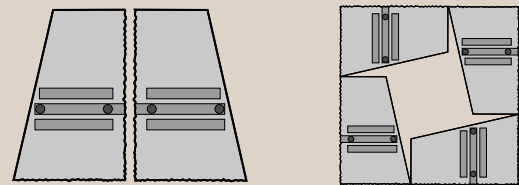





Tribute Retaining Wall System – Canyon Brown  
with Elements Paving Stones – Timeless,  
and Crest Bullnose Pavers – Timeless  
(Shown with Square Steel Fire Pit Insert)



Tribute Retaining Wall System – Silverstone

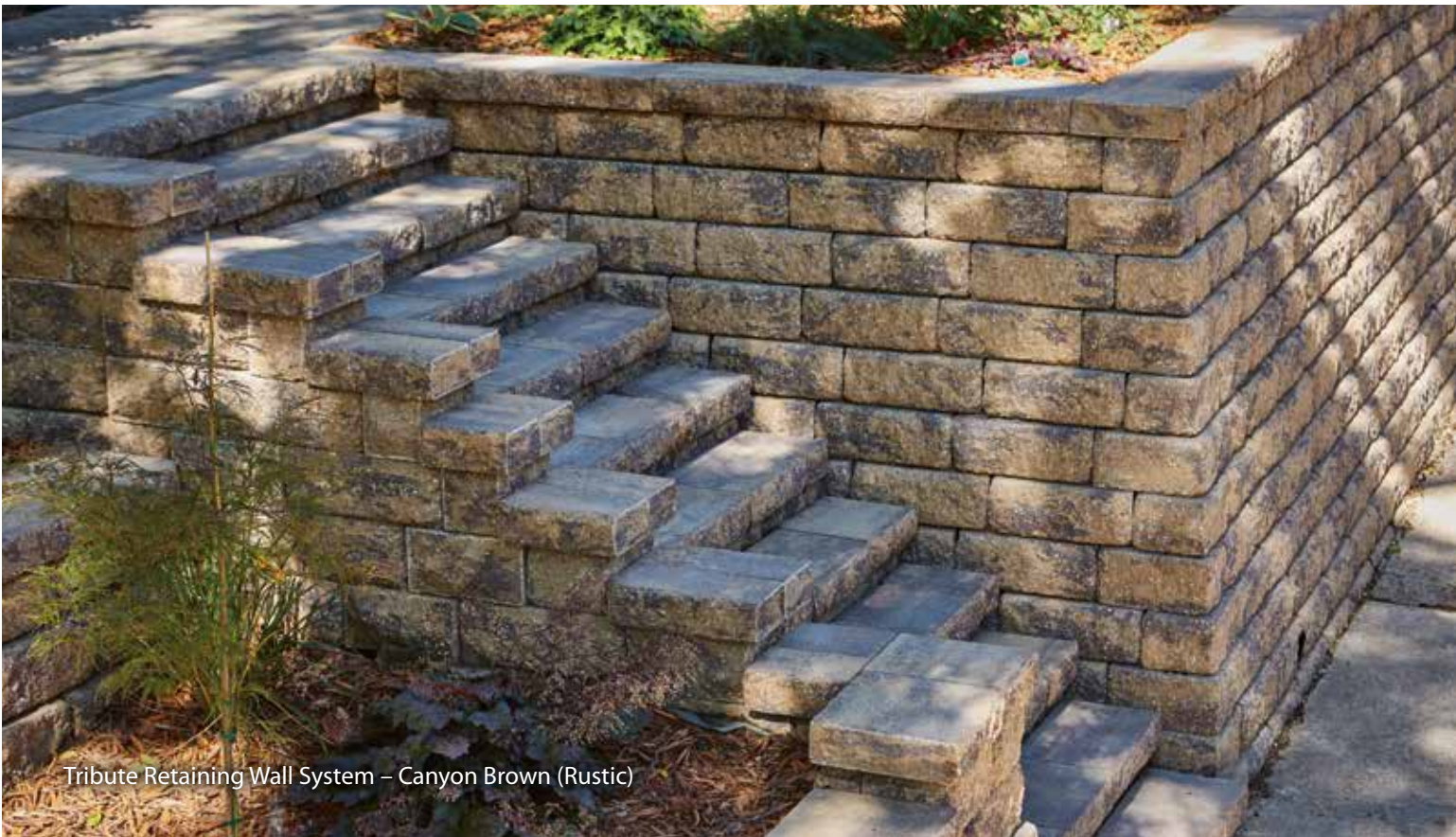

Tribute Retaining Wall System – Canyon Brown (Rustic)





Tribute Retaining Wall System – Canyon Brown



Tribute Retaining Wall System – Silvertone



*HNA Award Winner – 2018*



County Block Retaining Wall System – Swiss Mocha,  
Summit Stone Landscape Units – Haven,  
Grand Milestone – Haven, Crest Bullnose Pavers – Vision,  
Destination Pavers – Haven,  
and Elements Paving Stones – Reflection (border)



# County Block<sup>®</sup> Retaining Wall System

The County Block Retaining Wall System blends seamlessly in classic and contemporary landscape settings.



COUNTY  
**BLOCK**<sup>®</sup>  
RETAINING WALL SYSTEM





County Block Retaining Wall System – Canyon Brown with Destination Pavers – Haven

Designed with versatility in mind, **County Block® Retaining Wall System** is an impeccable solution for planting beds, steps or multi-level terraces. Installation is simple with its pin system. When filled with aggregate, the cored units provide one of the strongest and longest lasting connections available without the hassle or costs of mortar, special equipment or hard-to-find tools.

Crafted in a split face or rustic finish, County Block units harmonize with County Materials' line of landscaping products. Manufactured with high-strength and low absorption concrete and natural elements, the County Block Retaining Wall System is designed to withstand weather extremes while offering years of maintenance-free beauty.

## Sizes County Block Retaining Wall System

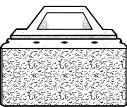
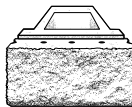
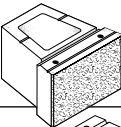
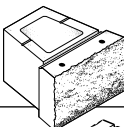
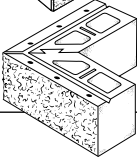
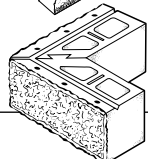
Splitface	Rustic	D x H x L (Nominal Size) Inches • Millimeters	SF/ Unit	Units/ Pallet	Lbs/ Unit	Lbs/ Pallet
		12 x 7 <sup>5</sup> / <sub>8</sub> x 18 • 305 x 194 x 457 <b>Jumbo</b>	.95	50	68	3445
		12 x 7 <sup>5</sup> / <sub>8</sub> x 12 <sup>1</sup> / <sub>2</sub> • 305 x 194 x 318 <b>Standard</b>	.66	64	46	2965
		7 <sup>5</sup> / <sub>8</sub> x 7 <sup>5</sup> / <sub>8</sub> x 17 <sup>1</sup> / <sub>2</sub> • 194 x 194 x 445 <b>Corner</b>	.93	60	53	3225

- Calculate the number of:
  - County Block Standard units needed: SF x 1.5
  - County Block Jumbo units needed: SF x 1.05
- Calculate the equal number of both sizes blended into a County Block wall: SF divided by 1.61

**Note:** Retaining Wall Caps are available (Information is located on page 145).



# Color Options **County Block Retaining Wall System**

Manufactured at our Appleton, WI location

Blended Colors

Solid Colors

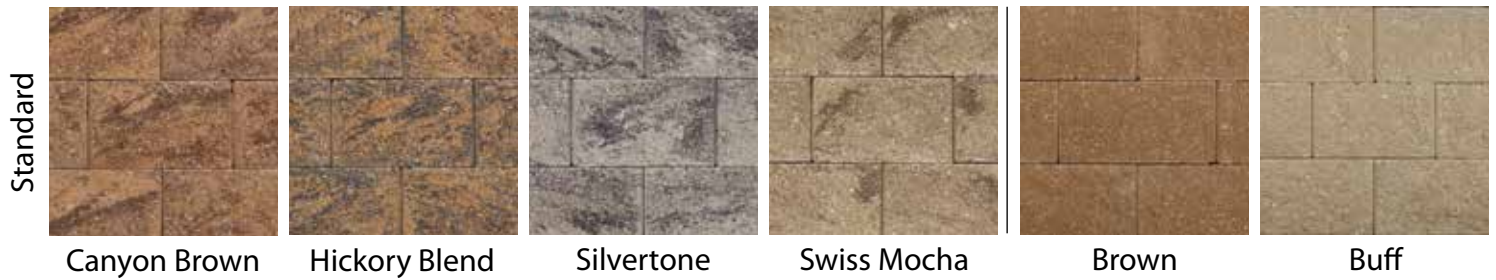

Manufactured at our Marathon, WI location

Blended Colors

Solid Colors



Manufactured at our Roberts, WI location

Blended Colors

Solid Colors







County Block Retaining Wall System – Canyon Brown  
with Summit Stone Landscape Units – Hush and Haven



County Block Retaining Wall System – Canyon Brown  
with Destination Pavers – Serenity





County Block Retaining Wall System – Silvertone (Heavy Rustic)  
with Elements Paving Stones – Timeless (Barrel Tumbled)



County Block Retaining Wall System – Hickory Blend



County Block Retaining Wall System – Swiss Mocha  
with Summit Stone Landscape Units – Haven







# Integrity™ Retaining Wall System

Integrity Retaining Wall System's unit size and scale make it perfect for larger, impressive wall projects.

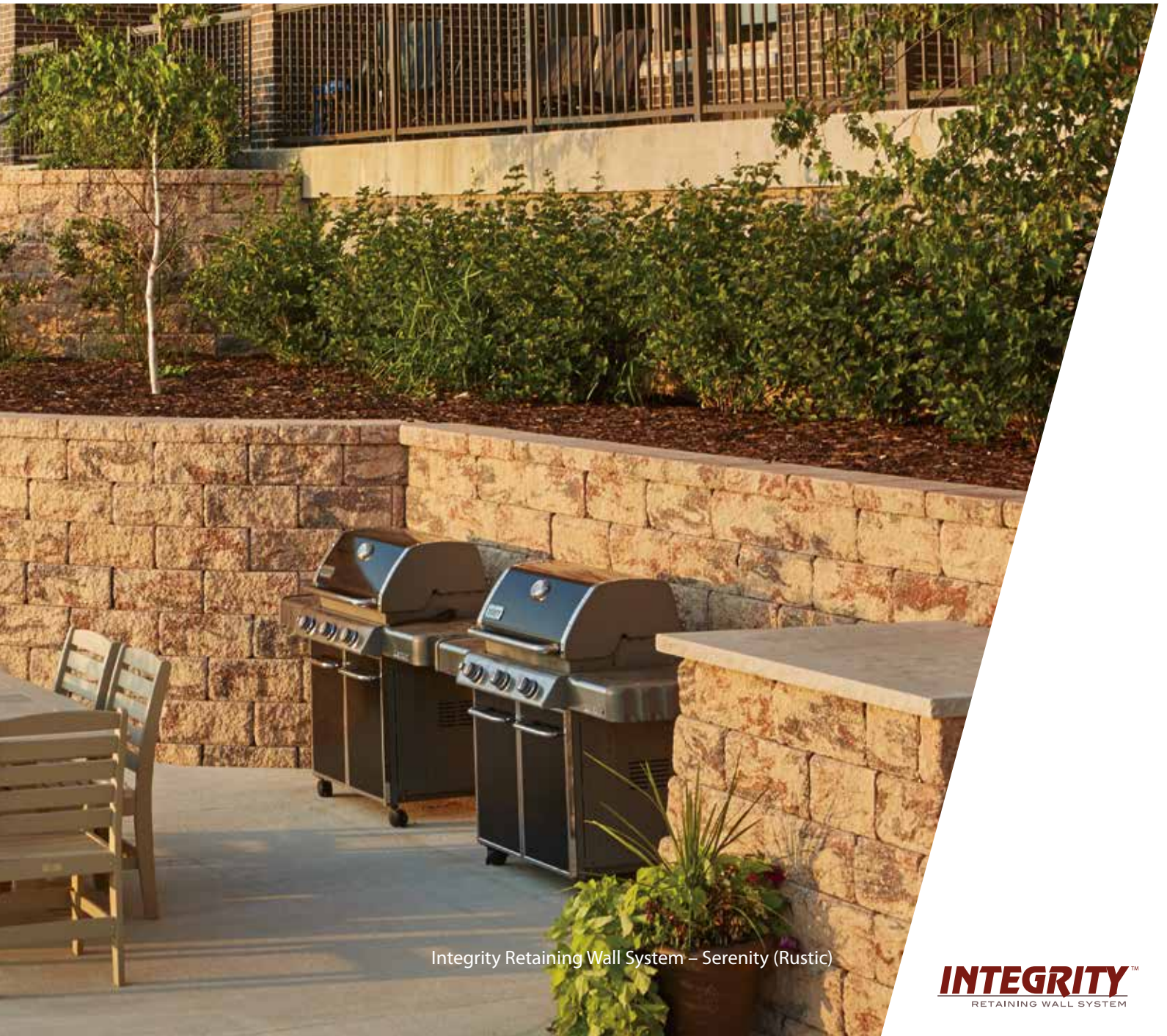

Integrity Retaining Wall System – Serenity (Rustic)

**INTEGRITY™**  
RETAINING WALL SYSTEM





Integrity Retaining Wall System – Serenity  
with Destination Pavers – Serenity

The **Integrity™ Retaining Wall System** is a practical solution for even challenging applications, including multi-level terraces and slope protection. Manufactured with a rear lip design and high-density concrete, the Integrity Retaining Wall System ensures efficient installation, increased stability and lasting durability. Units are available in natural-looking Splitface or weathered Rustic options.

## Sizes Integrity Retaining Wall System

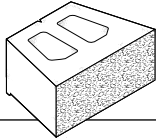
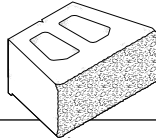
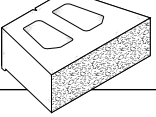
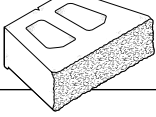
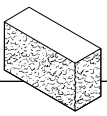
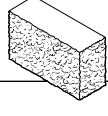
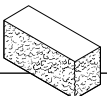
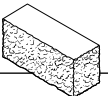
		D X H X L (Nominal Size) Inches • Millimeters	SF/ Unit	Units/ Pallet	Lbs/ Unit	Lbs/ Pallet
<b>Splitface</b>	<b>Rustic</b>	12 x 8 x 18 • 305 x 203 x 457 <b>Standard</b>	1	36	80	2925
						
		12 x 6 x 18 • 305 x 152 x 457 <b>Junior</b>	.75	32	63	2060
		3 <sup>5</sup> / <sub>8</sub> x 8 x 12 • 92 x 203 x 305 <b>Standard Corner</b>	.67	60	27	1665
		3 <sup>5</sup> / <sub>8</sub> x 6 x 12 • 92 x 152 x 305 <b>Junior Corner</b>	.5	60	20	1260

**Note:** Retaining Wall Caps are available (Information is located on page 145).



# Color Options Integrity Retaining Wall System

## Blended Colors

## Solid Colors



• Also available in Heavy Rustic.

*The color photos shown in this catalog were prepared with careful attention to accuracy. However, colors shown may vary from actual hues and should only be used as a guide. Refer to actual product samples for final color selection. Because concrete units are manufactured with high quality, naturally-mined aggregates and materials, variations in color or shading should be expected in products that are manufactured at different times and in units having different shapes. This color or shading variation is acceptable in the industry.*



Integrity Retaining Wall System – Hush





Integrity Retaining Wall System – Gray (Rustic)

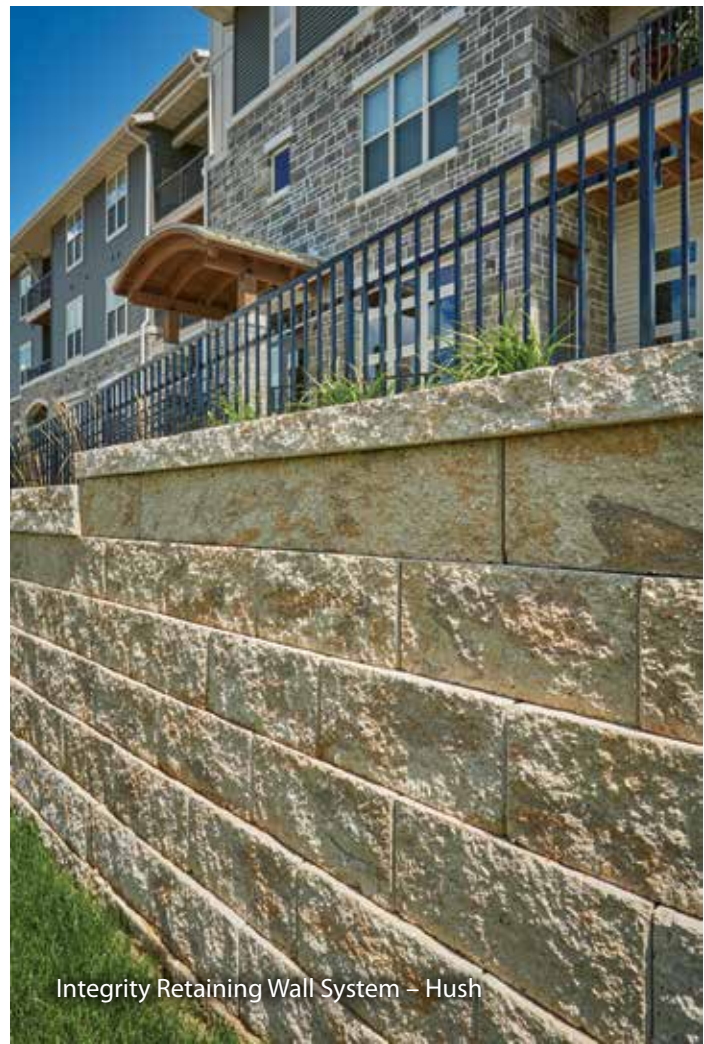

Integrity Retaining Wall System – Hush



Integrity Retaining Wall – Serenity  
with Oversize Landscape Step Units – Camel





Integrity Retaining Wall System – Timeless (Rustic)



Integrity Retaining Wall System – Haven







# Winston<sup>®</sup> Retaining Wall System

Available in a straight and tri-split face design, the Winston Retaining Wall System is the right choice for one-of-a-kind landscaping results.

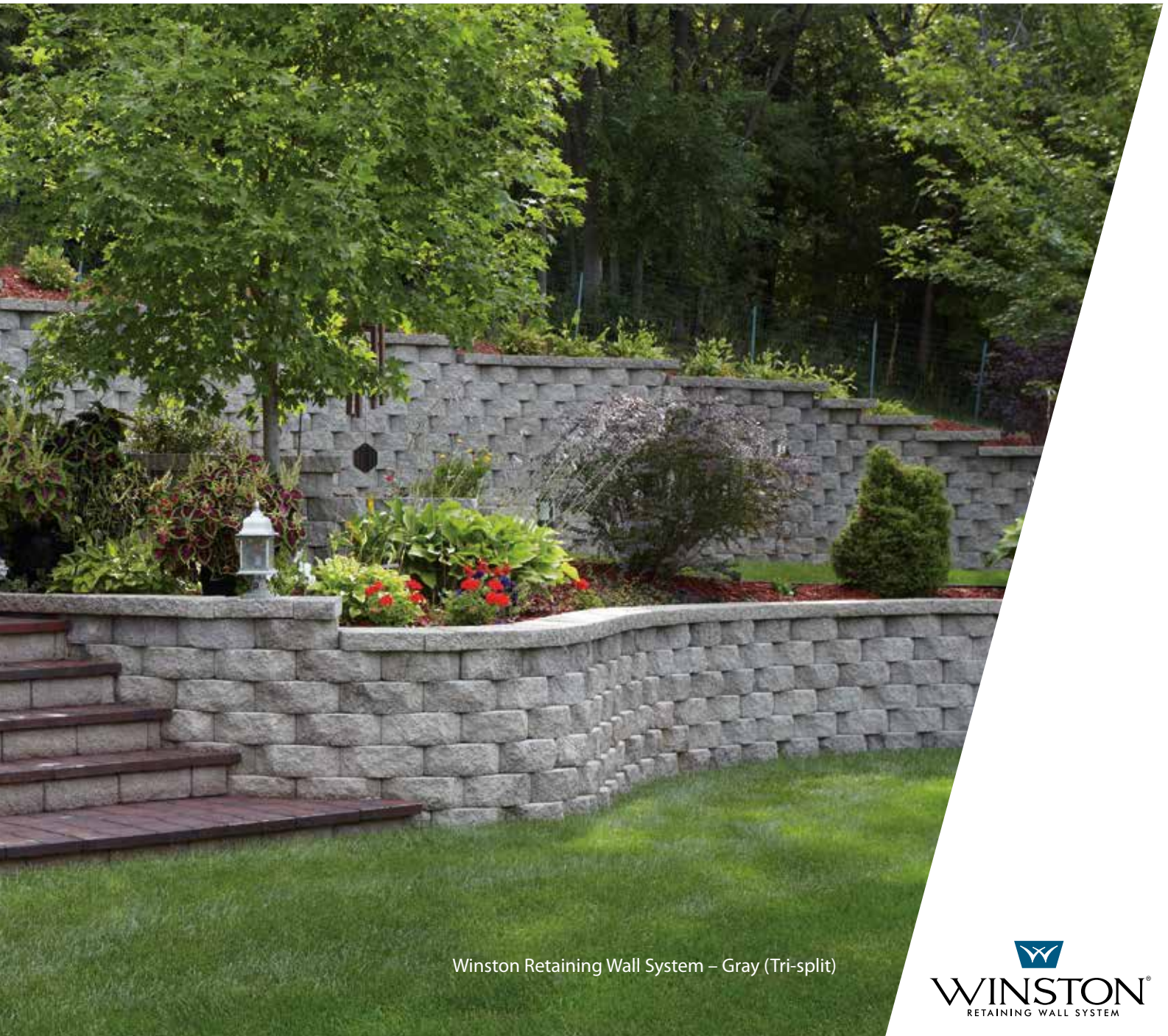

Winston Retaining Wall System – Gray (Tri-split)







Winston Retaining Wall System – Brown (Tri-split)

**Winston® Retaining Wall System's** full cores and built-in drainage provide strength and lasting performance. With their built-in setback design, Winston units install quickly and offer the correct slope for a stable wall. Form curved walls, steps, terraces and many other creative applications with this appealing wall system.

## Sizes Winston Retaining Wall System

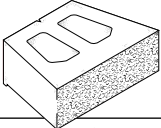
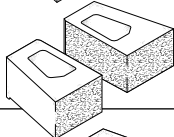
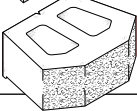
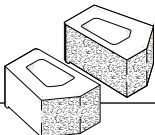
	D x H x L (Nominal Size) Inches • Millimeters	SF/ Unit	Units/ Pallet	Lbs/ Unit	Lbs/ Pallet
	12 x 6 x 17½ • 305 x 152 x 445 <b>Straight</b>	.73	54	64	3501
	12 x 6 x 8¾ • 305 x 152 x 222 <b>Straight Corner</b>	.36	108	33	3609
	12 x 6 x 16 • 305 x 152 x 406 <b>Tri-Split</b>	.67	54	60	3285
	12 x 6 x 8 • 305 x 152 x 203 <b>Tri-Split Corner</b>	.33	108	32	3501

**Note:** Only available in select markets. Contact your County Materials' representative for details.  
Retaining Wall Caps are available (Information is located on page 145).  
Solid-top Units are also available.



# Color Options Winston Retaining Wall System

## Blended Colors

## Solid Colors

Standard  
(Straight)



Canyon Brown

Silvertone

Brown

Gray

(Colors shown are also available in Tri-Split units).

*The color photos shown in this catalog were prepared with careful attention to accuracy. However, colors shown may vary from actual hues and should only be used as a guide. Refer to actual product samples for final color selection. Because concrete units are manufactured with high quality, naturally-mined aggregates and materials, variations in color or shading should be expected in products that are manufactured at different times and in units having different shapes. This color or shading variation is acceptable in the industry.*



Winston Retaining Wall System – Brown (Tri-split)



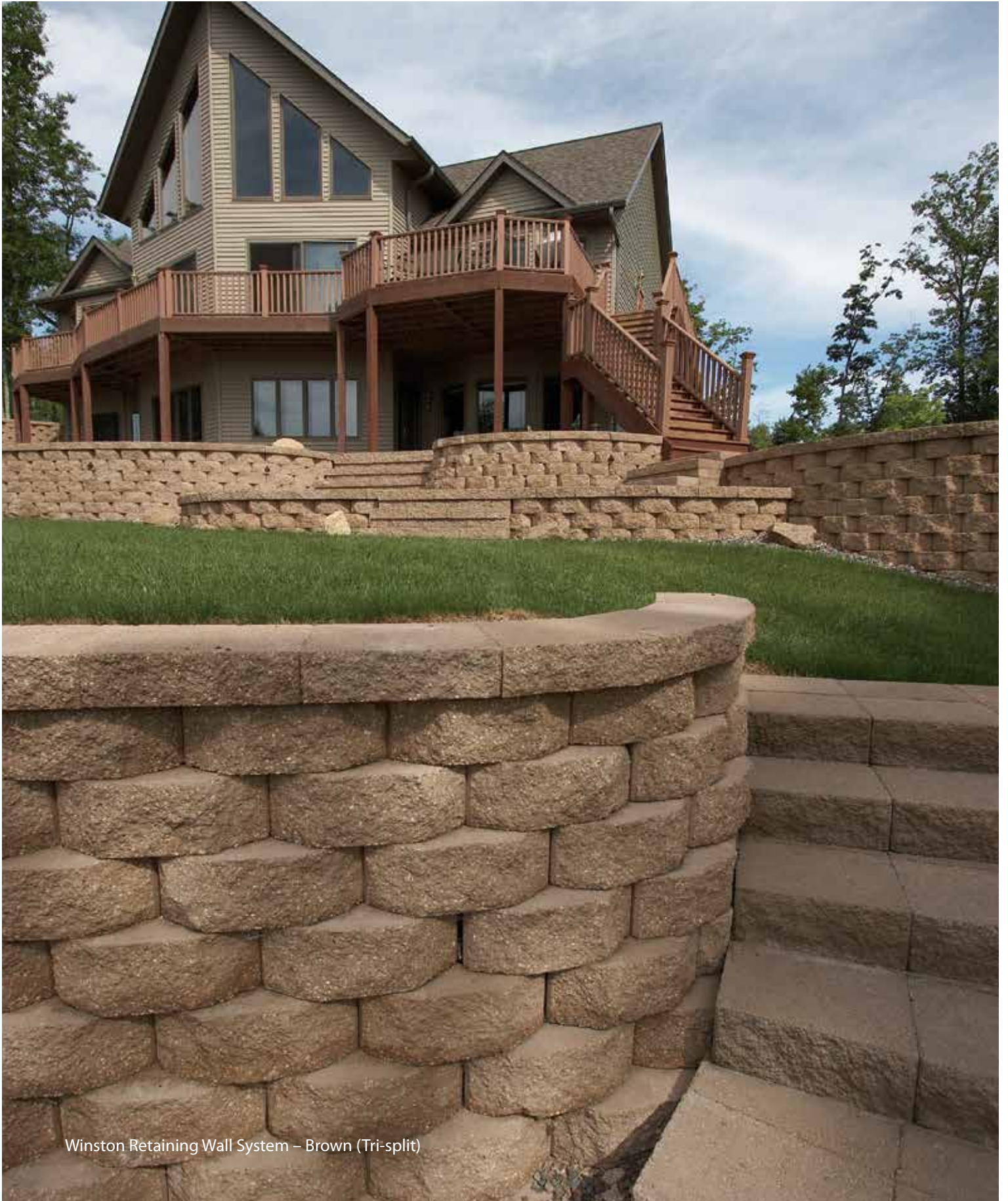

Winston Retaining Wall System – Brown (Tri-split)



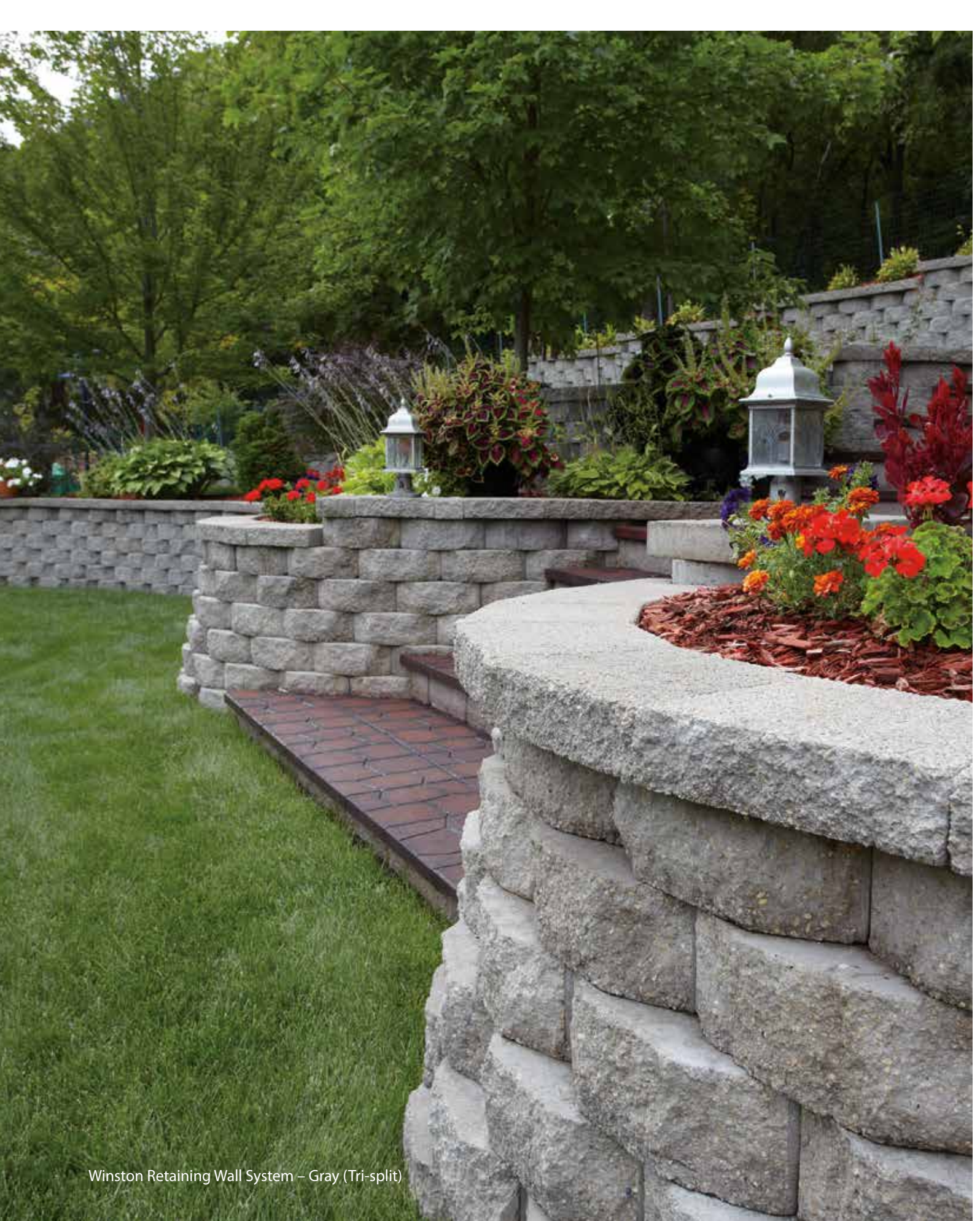

Winston Retaining Wall System – Gray (Tri-split)







# Terrace Stone<sup>®</sup> Retaining Wall System

Bring depth and distinct beauty to landscape projects with the Terrace Stone Retaining Wall System.



Terrace Stone Retaining Wall System – Brown (Tri-split)

**TERRACE STONE<sup>®</sup>**  
RETAINING WALL SYSTEM





Terrace Stone Retaining Wall System – Gray (Tri-split)

The **Terrace Stone® Retaining Wall System** is manufactured with a tri-split face that resembles natural cut stone, Terrace Stone brings shadows out in the open. An interlocking design allows for efficient installation and a structurally sound wall.

## Sizes Terrace Stone Retaining Wall System

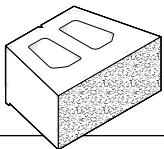
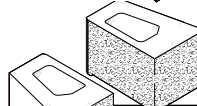
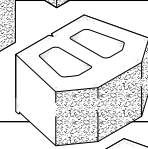
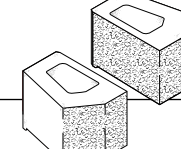
	D x H x L (Nominal Size) Inches • Millimeters	SF/ Unit	Units/ Pallet	Lbs/ Unit	Lbs/ Pallet
	12 x 8 x 17½ • 305 x 203 x 444 <b>Straight</b>	.97	36	86	3146
	12 x 8 x 8¾ • 305 x 203 x 222 <b>Straight Corner</b>	.49	72	43	3146
	12 x 8 x 16 • 305 x 203 x 406 <b>Tri-Split</b>	.89	36	75	2745
	12 x 8 x 8 • 305 x 203 x 203 <b>Tri-Split Corner</b>	.44	72	40	2925

**Note:** Only available in select markets. Contact your County Materials' representative for details.  
Retaining Wall Caps are available (Information is located on page 145).



# Color Options Terrace Stone Retaining Wall System



*The color photos shown in this catalog were prepared with careful attention to accuracy. However, colors shown may vary from actual hues and should only be used as a guide. Refer to actual product samples for final color selection. Because concrete units are manufactured with high quality, naturally-mined aggregates and materials, variations in color or shading should be expected in products that are manufactured at different times and in units having different shapes. This color or shading variation is acceptable in the industry.*



Terrace Stone Retaining Wall System – Brown (Tri-split)





Terrace Stone Retaining Wall System – Brown (Tri-split)





Terrace Stone Retaining Wall System – Brown (Tri-split)



Terrace Stone Retaining Wall System – Gray (Tri-split)





Navaro Retaining Wall System – Canyon Brown  
with County Block Retaining Wall System – Canyon Brown,  
Destination Pavers – Haven,  
and Oversize Landscape Step Units – Camel



# Navaro<sup>®</sup> Retaining Wall System

Structural strength and distinctive character are combined in the Navaro Retaining Wall System.



**Navaro**<sup>®</sup>  
Retaining Wall System





Navaro Retaining Wall System – Canyon Brown  
with County Block Retaining Wall System – Canyon Brown

The **Navaro® Retaining Wall System** rounded split face affords a hand-cut stone appearance. High-strength polyresin pins firmly lock each unit into place and ensure accurate alignment. The Navaro Retaining Wall System is an ideal solution for raised patios, steps, planting beds, erosion control and terraces. With geosynthetic reinforcement and engineering, taller Navaro Retaining Walls can be constructed.

## Sizes Navaro Retaining Wall System

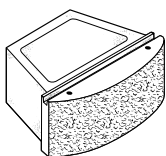

D X H X L (Nominal Size)  
Inches • Millimeters

12 x 7<sup>5</sup>/<sub>8</sub> x 17<sup>3</sup>/<sub>8</sub> • 305 x 194 x 441

**Standard**

SF/ Unit	Units/ Pallet	Lbs/ Unit	Lbs/ Pallet
-------------	------------------	--------------	----------------

.92

50

70

3545

• Calculate the number of Navaro units needed: SF x 1.08

**Note:** Retaining Wall Caps are available (Information is located on page 145).



# Color Options Navaro Retaining Wall System



*The color photos shown in this catalog were prepared with careful attention to accuracy. However, colors shown may vary from actual hues and should only be used as a guide. Refer to actual product samples for final color selection. Because concrete units are manufactured with high quality, naturally-mined aggregates and materials, variations in color or shading should be expected in products that are manufactured at different times and in units having different shapes. This color or shading variation is acceptable in the industry.*

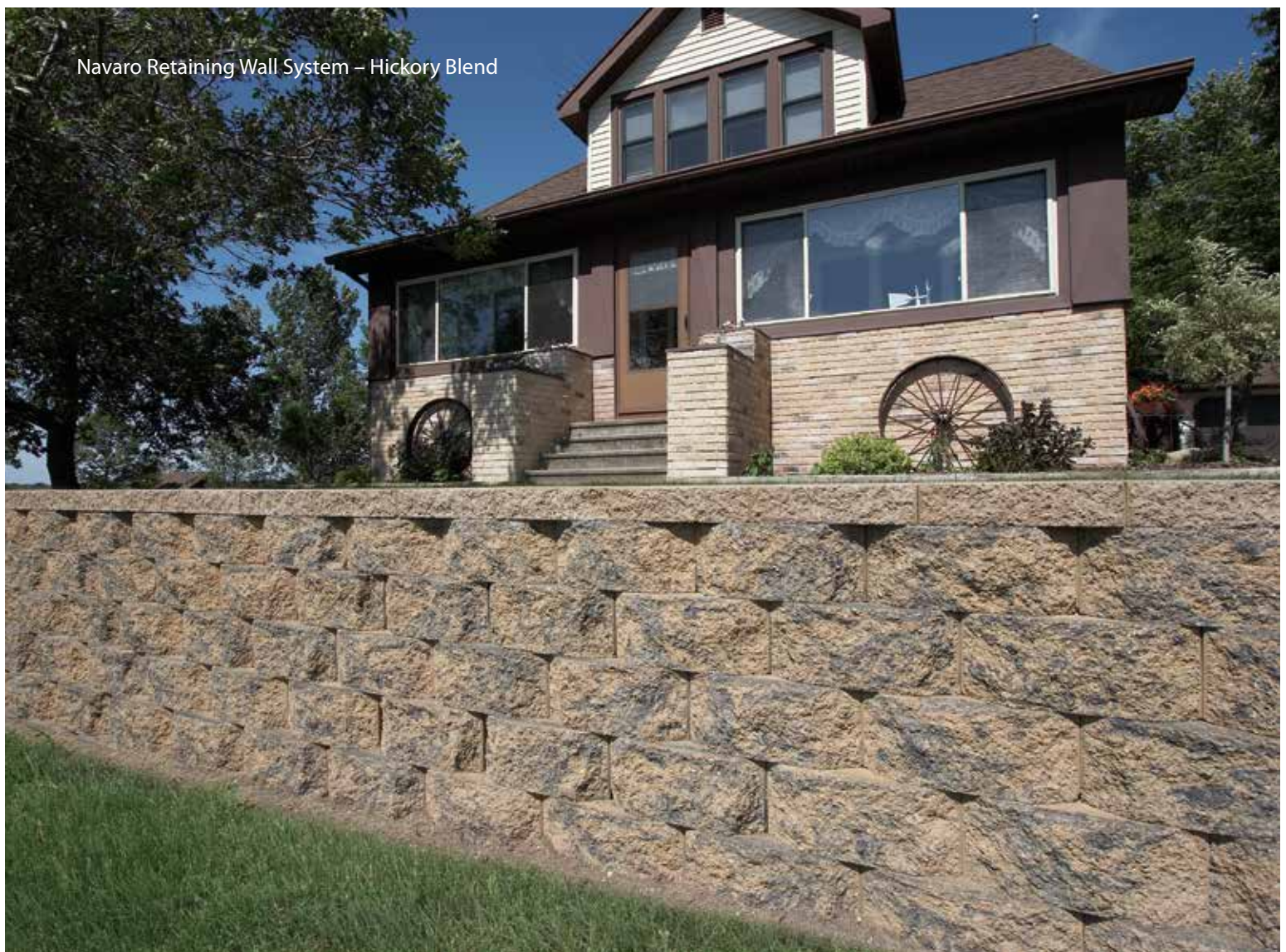





Navaro Retaining Wall System – Canyon Brown



Navaro Retaining Wall System – Hickory Blend



Navaro Retaining Wall System – Hickory Blend

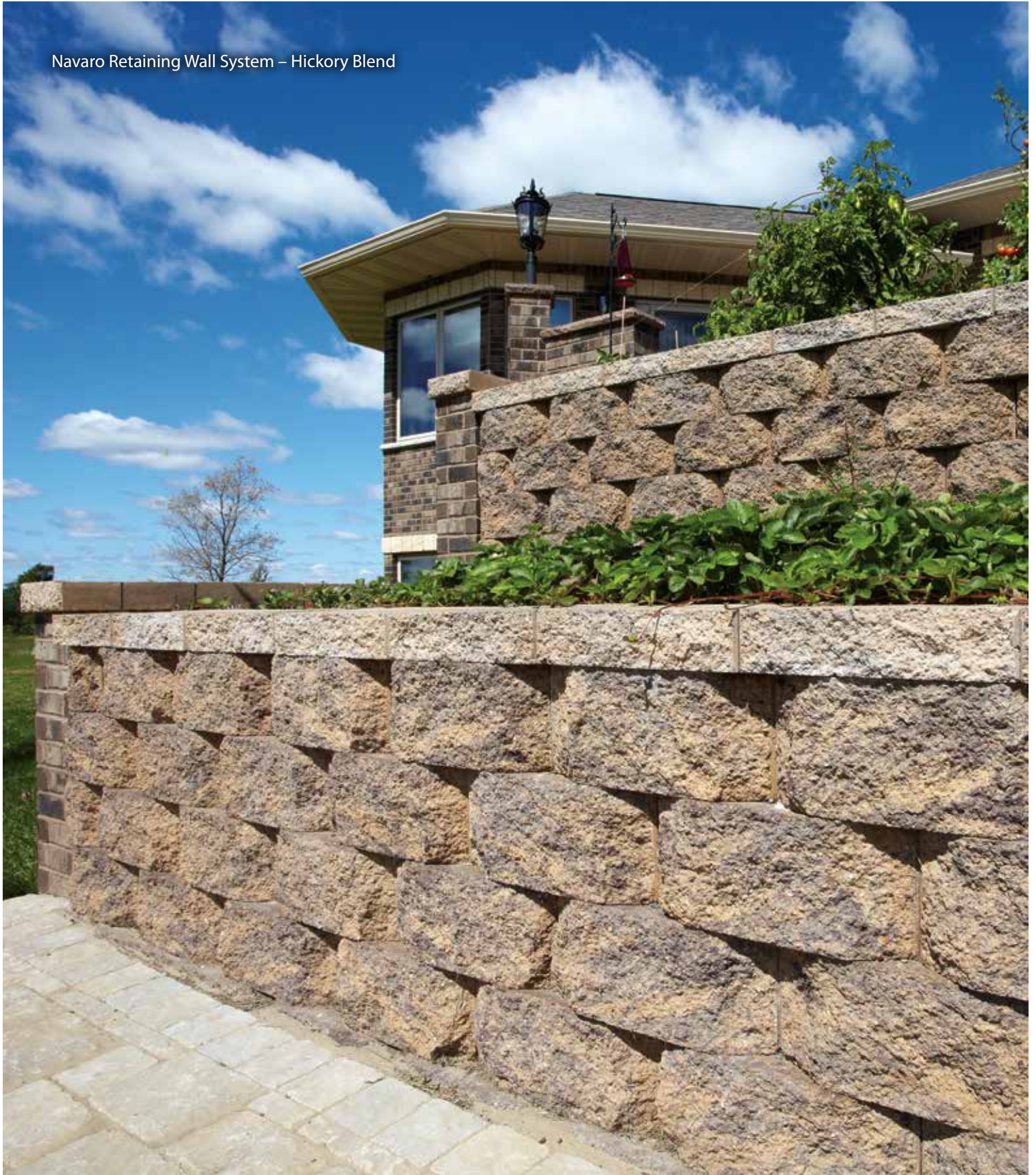



County Cub Landscape Units – Silvertone

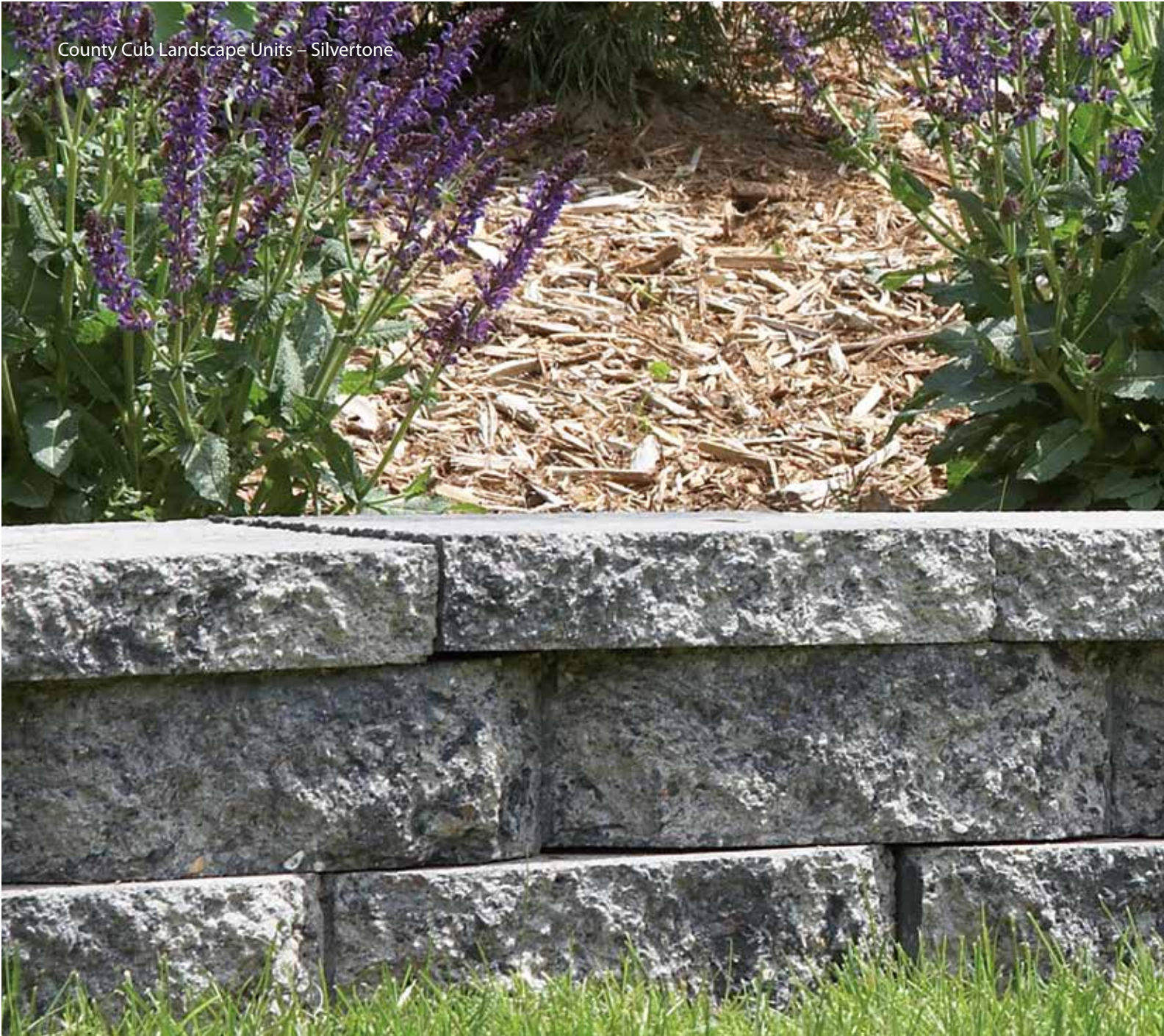



# County Cub<sup>®</sup> Landscape Units

Ideal for low walls as well as subtle transitions and landscape accents, County Cub Landscape Units offer a natural stone appearance.







**County Cub® Landscape Units** are available in a range of earthy colors to compliment the rich hues of County Materials’ paving stones. With their smaller scale and compact design, County Cubs can be quickly and easily installed to create a distinctive look in any lawn or garden setting.

## Sizes **County Cub Landscape Units**

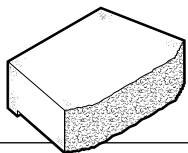

D x H x L (Nominal Size)  
Inches • Millimeters

8 x 3<sup>5</sup>/<sub>8</sub> x 12 • 203 x 92 x 305  
**Standard**

SF/ Unit	Units/ Pallet	Lbs/ Unit	Lbs/ Pallet
-------------	------------------	--------------	----------------

.30	168	22	3750
-----	-----	----	------

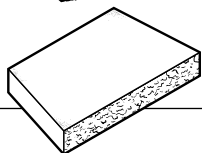

8 x 2 x 13<sup>3</sup>/<sub>8</sub> • 203 x 51 x 340  
**Tapered Cap**

–	108	16	1773
---	-----	----	------

• Calculate the number of County Cub units needed: SF x 3.3



# Color Options **County Cub Landscape Units**

## Blended Colors



## Solid Colors

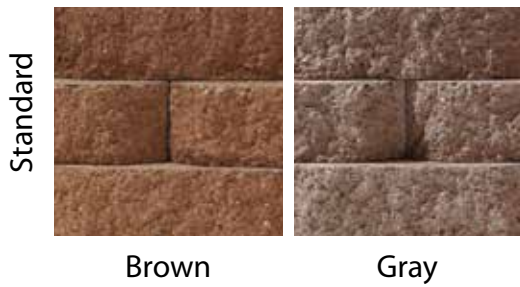

*The color photos shown in this catalog were prepared with careful attention to accuracy. However, colors shown may vary from actual hues and should only be used as a guide. Refer to actual product samples for final color selection. Because concrete units are manufactured with high quality, naturally-mined aggregates and materials, variations in color or shading should be expected in products that are manufactured at different times and in units having different shapes. This color or shading variation is acceptable in the industry.*



County Cub Landscape Units – Canyon Brown





Landscape Step Units – Sandstone



# Landscape Step Units

Landscape Step Units feature a natural-looking stone texture on their front face and decorative beveled front edge that compliments County Materials' pavers and retaining wall systems.





Landscape Step Units – Sandstone



**Landscape Step Units** smooth stepping surface provides solid and safe footing. Their size speeds up installation time for steps and reduces the amount of retaining wall block needed. Landscape Step Units can also be cut onsite to fit project needs.

## Sizes Landscape Step Units

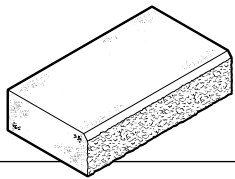

D x H x L (Nominal Size)  
Inches

14 x 6 x 24

Units/ Pallet	Lbs/ Unit	Lbs/ Pallet
------------------	--------------	----------------

10

164

1680

## Color Options Landscape Step Units

Solid Colors

Standard



Charcoal

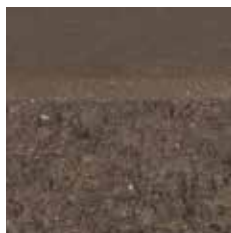

Dark Brown



Gray



Sandstone

*The color photos shown in this catalog were prepared with careful attention to accuracy. However, colors shown may vary from actual hues and should only be used as a guide. Refer to actual product samples for final color selection. Because concrete units are manufactured with high quality, naturally-mined aggregates and materials, variations in color or shading should be expected in products that are manufactured at different times and in units having different shapes. This color or shading variation is acceptable in the industry.*



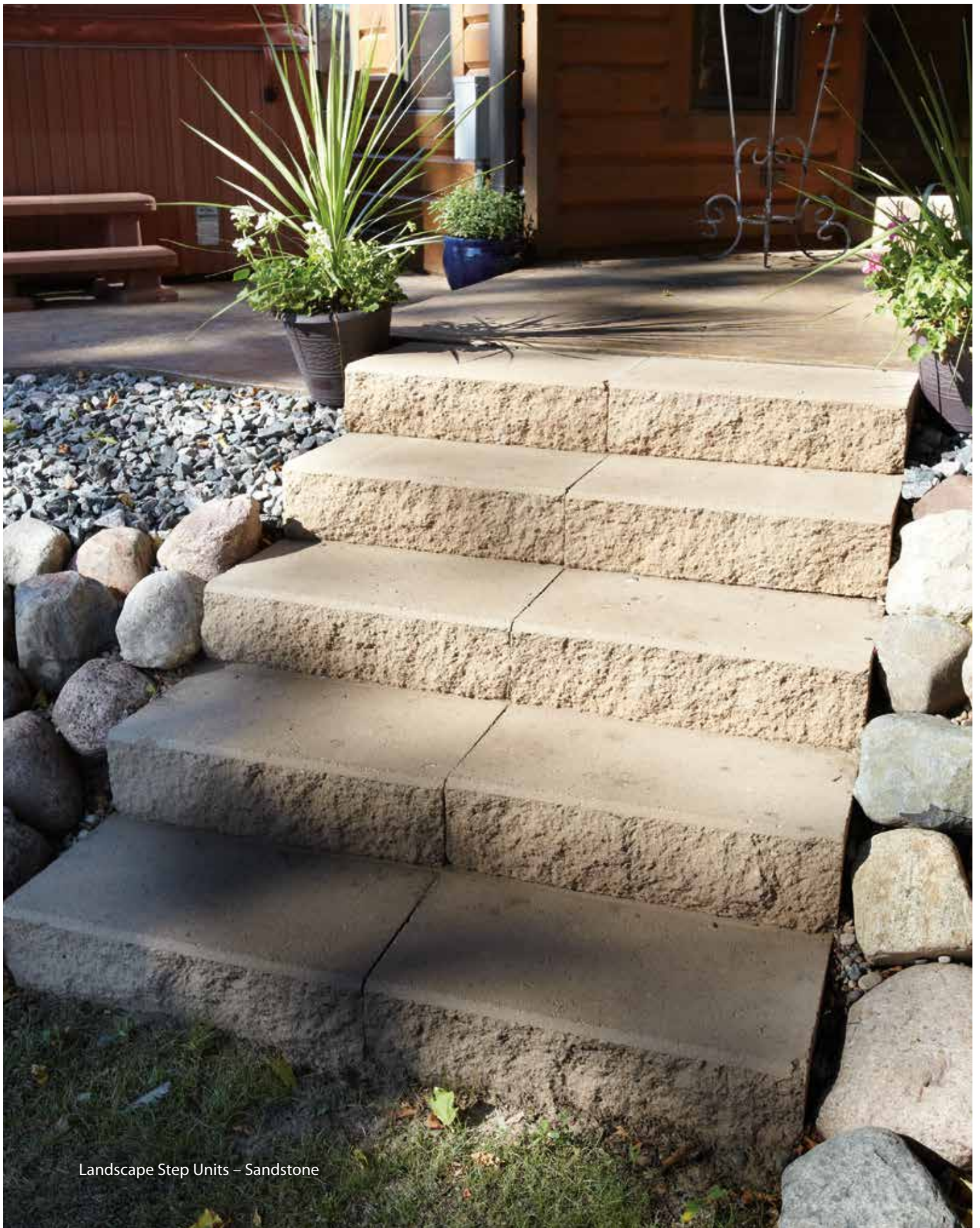

Landscape Step Units – Sandstone







# Oversize Landscape Step Units

Oversize Landscape Step Units are a functional option for a variety of step applications, including traditional or free-flowing staircases, landings, water features, walls or accents.







Oversize Landscape Step Units – Gray

The optimal finishing touch to any landscaping masterpiece: **Oversize Landscape Step Units**. Manufactured with uniform heights and a naturally textured surface, their consistent rise enhances pedestrian comfort and safety. Their larger scale also covers more square footage than alternative step options, speeding installation and reducing labor costs. With their natural rock outcropping appearance, Oversized Landscape Step Units offer an organic appeal to landscape projects.

## Sizes Oversize Landscape Step Units

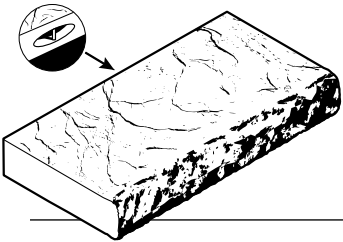

D x H x L (Nominal Size)  
Inches

25 x 6¼ x 48

Units/ Pallet	Lbs/ Unit	Lbs/ Pallet
------------------	--------------	----------------

4

760

3085

## Color Options Oversize Landscape Step Units

Solid Colors

Standard



Camel



Gray



Portobello

*The color photos shown in this catalog were prepared with careful attention to accuracy. However, colors shown may vary from actual hues and should only be used as a guide. Refer to actual product samples for final color selection. Because concrete units are manufactured with high quality, naturally-mined aggregates and materials, variations in color or shading should be expected in products that are manufactured at different times and in units having different shapes. This color or shading variation is acceptable in the industry.*





Oversize Landscape Step Units – Camel

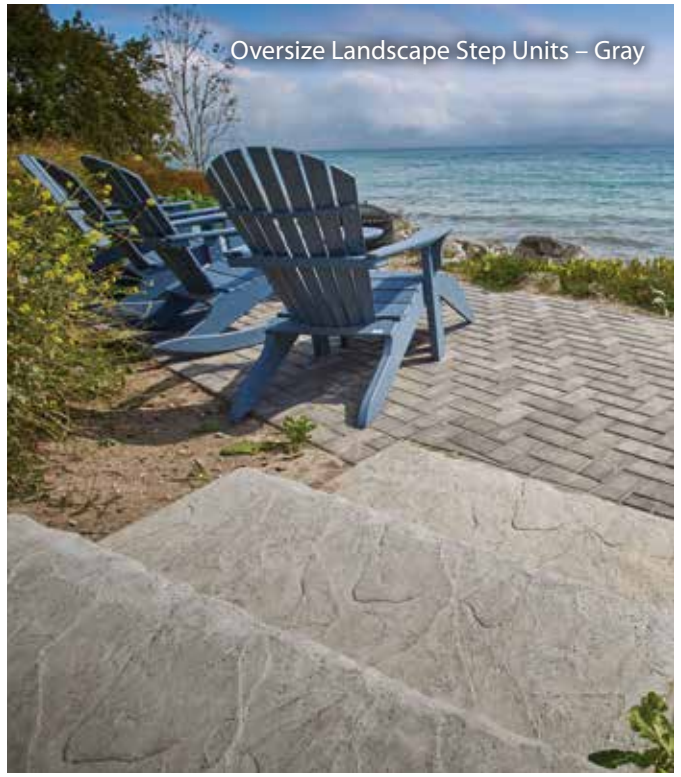

Oversize Landscape Step Units – Gray



Oversize Landscape Step Units – Portobello  
and County Block Retaining Wall System – Canyon Brown



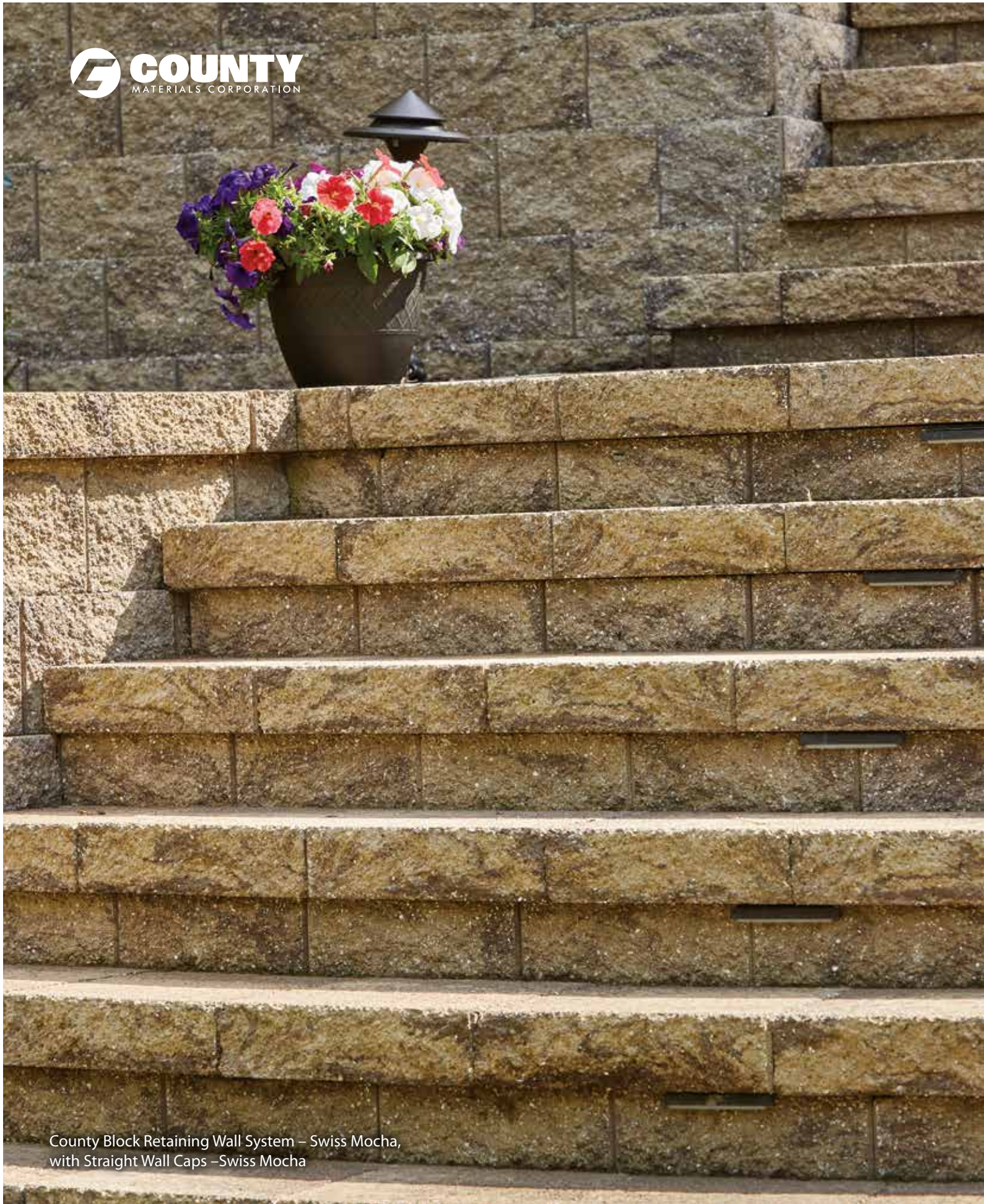

County Block Retaining Wall System – Swiss Mocha,  
with Straight Wall Caps – Swiss Mocha



# Related Retaining Wall Items

## Wall Caps



Splitface



Rustic

### Splitface

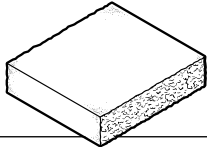

### Rustic

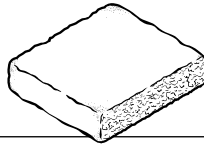

D x H x L (Nominal Size)  
Inches • Millimeters

12 x 3<sup>5</sup>/<sub>8</sub> x 15<sup>1</sup>/<sub>2</sub> • 305 x 92 x 394  
**Straight Wall Cap**

SF/ Unit	Units/ Pallet	Lbs./ Unit	Lbs./ Pallet
-------------	------------------	---------------	-----------------

- 70 54 3805

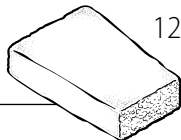
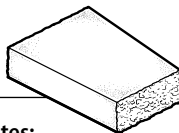

12<sup>3</sup>/<sub>4</sub> x 3<sup>5</sup>/<sub>8</sub> x 7<sup>7</sup>/<sub>8</sub> -9<sup>3</sup>/<sub>8</sub> • 324 x 92 x 200-238  
**Tapered Wall Cap**

- 90 30 2605

### Notes:

- Split on one side
- Also available in Heavy Rustic texture
- Color options for wall caps will vary depending on the retaining wall units they are ordered with. Contact your County Materials' representative for wall cap colors.

## Adhesive

Product	Case Qty.
SRW Adhesive 10.5 oz.	12
SRW Adhesive 29 oz.	12

## Landscape Fabric

Product
Mirandscape 3' x 300' (per sq yd)
SRW 3' x 50' (per roll)
SRW 3' x 300' (per roll)
SRW 4' x 300' (per roll)
SRW 6' x 300' (per roll)
SRW 12' x 300' (per roll)

## Geogrid

Product
SRW 3- 6' x 50' (per roll)
SRW 3- 6' x 150' (per roll)
SRW 3- 12' x 150' (per roll)
SRW 5- 6' x 150' (per roll)
SRW 7- 12' x 150' (per roll)

## Bin Block

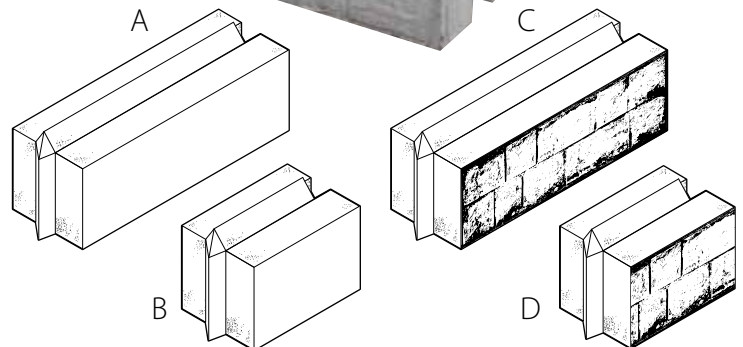
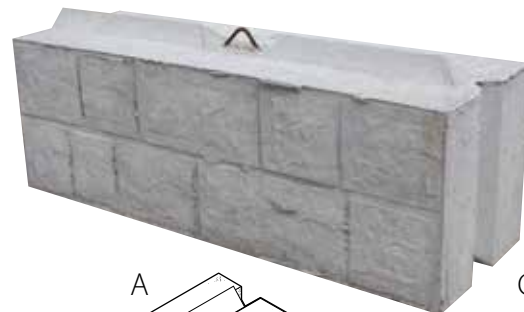

Product	Size D x H x L (inches)	SF/ Unit	Units/ Pallet	Lbs./ Unit	Lbs./ Pallet
Full Bin Block-Smooth-A	24 x 24 x 72	12	1	3600	3645
Half Bin Block-Smooth-B	24 x 24 x 36	6	1	1800	1845
Full Bin Block-Cutstone-C	24 x 24 x 72	12	1	3600	3645
Half Bin Block-Cutstone-D	24 x 24 x 36	6	1	1800	1845

- Caps are available (24 x 6 x 72)
- Contact Sales Representative for Smooth Top Availability.





Summit Stone Landscape Units – Haven,  
County Block Retaining Wall System – Swiss Mocha,  
Grand Milestone – Haven, Crest Bullnose Pavers – Vision,  
Destination Pavers – Haven,  
and Elements Paving Stones – Reflection (border)



# Outdoor Living Products

- Summit Stone® Landscape Units
- Reflection Stone® Masonry Units

## Related Outdoor Living Items:

- Isokern Fireplace & Chimney Components
- Fire Pit Inserts



Summit Stone Landscape Units – Haven and Timeless, and Tranquility Pavers – Haven (with border of Elements Paving Stones – Reflection)

*The color photos shown in this catalog were prepared with careful attention to accuracy. However, colors shown may vary from actual hues and should only be used as a guide. Refer to actual product samples for final color selection. Because concrete units are manufactured with high quality, naturally-mined aggregates and materials, variations in color or shading should be expected in products that are manufactured at different times and in units having different shapes. This color or shading variation is acceptable in the industry.*





Summit Stone Landscape Units – Timeless and Hush



# Summit Stone<sup>®</sup> Landscape Units

Summit Stone Landscape Units offer incredible design flexibility for creating almost any outdoor landscape features. Available in tumbled or smooth finish.







Summit Stone Landscape Units – Haven  
with Tranquility Pavers – Haven,  
and Elements Paving Stones – Reflection (border)

**Summit Stone® Landscape Units'** dimensional shape and multiple unit sizes make them ideal for constructing custom outdoor fireplaces and kitchens, built in grills, seat walls, pillars and more. Summit Stone's weathered finish is the crowning touch that compliments County Materials' line of landscaping products.

## Sizes Summit Stone Landscape Units

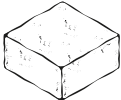
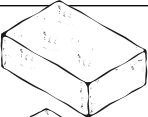
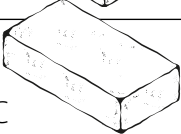
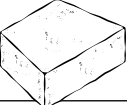
	D x H x L (Nominal Size) Inches • Millimeters	SF/ Unit	Units/ SF	SF/ Layer	Layers/ Pallet	SF/ Pallet	Units/ Layer	Units/ Pallet	Lbs/ Unit	Lbs/ Pallet
A 	7¼ x 3⅝ x 7¼ • 184 x 92 x 184	.18	5.55	5.40	8	43.20	30	240	14	3410
B 	7¼ x 3⅝ x 10⅞ • 184 x 92 x 276	.27	3.70	5.40	8	43.20	20	160	21	3410
C 	7¼ x 3⅝ x 14½ • 184 x 92 x 368	.37	2.70	5.55	8	44.40	15	120	28	3410
G 	7¼ x 3⅝ x 10⅞ • 184 x 92 x 276	.27	3.70	6.48	7	45.36	24	168	17.9	3097

## Layer Patterns Summit Stone Landscape Units

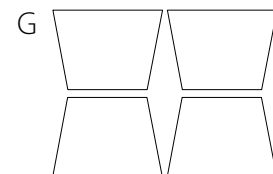
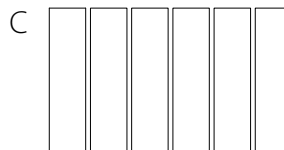
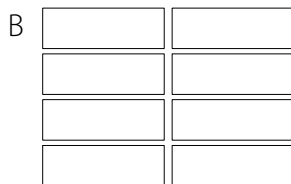
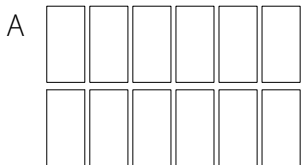



# Color Options Summit Stone Landscape Units

**NEW Colors for 2019!**

Our beautiful blended colors (along with two solid colors) are now available in a **smooth-textured** Summit Stone surface!



The color photos shown in this catalog were prepared with careful attention to accuracy. However, colors shown may vary from actual hues and should only be used as a guide. Refer to actual product samples for final color selection. Because concrete units are manufactured with high quality, naturally-mined aggregates and materials, variations in color or shading should be expected in products that are manufactured at different times and in units having different shapes. This color or shading variation is acceptable in the industry.



Summit Stone Landscape Units – Solace with H<sub>2</sub>O Pro Pavers – Serenity (Shown with optional Steel Fire Pit Insert)



# Fireplaces Summit Stone Landscape Units

## Summit Stone Standard Fireplace



### Standard Fireplace components include:

- (5) - 6" concrete block
- (5) - 3" soaps
- (14) - Summit Stone (7<sup>1</sup>/<sub>4</sub>" x 3<sup>5</sup>/<sub>8</sub>" x 10<sup>7</sup>/<sub>8</sub>") units special cut (1/3 and 2/3)
- (1) - 10 lbs. pail of Heat Stop II refractory clay
- (75) - fire brick 2<sup>1</sup>/<sub>2</sub>" thick
- (1) - 47" x 3<sup>1</sup>/<sub>2</sub>" x 3<sup>1</sup>/<sub>2</sub>" steel lintel
- (1 left and 1 right) - Summit Stone (7<sup>1</sup>/<sub>4</sub>" x 3<sup>5</sup>/<sub>8</sub>" x 10<sup>7</sup>/<sub>8</sub>") special cut lintel pad unit

• In addition to the standard fireplace components listed above, 320 Summit Stone (7<sup>1</sup>/<sub>4</sub>" x 3<sup>5</sup>/<sub>8</sub>" x 10<sup>7</sup>/<sub>8</sub>") are needed to complete project.

• Concrete adhesive is sold separately. Approx. 10-12 tubes of adhesive will be required, depending on the quantity applied to each Summit Stone.

Approx. 8000 lbs. - 3 total pallets

Product	Size D x H x L (inches)
Summit Fireplace Standard	54 <sup>3</sup> / <sub>4</sub> x 79 <sup>3</sup> / <sub>4</sub> x 84 <sup>1</sup> / <sub>4</sub>

## Summit Stone Double Woodbox Fireplace



### Double Woodbox Fireplace components include:

- (5) - 6" concrete block
- (16) - 4" concrete block
- (5) - 3" soaps
- (18) - Summit Stone (7<sup>1</sup>/<sub>4</sub>" x 3<sup>5</sup>/<sub>8</sub>" x 10<sup>7</sup>/<sub>8</sub>") units special cut (1/3 and 2/3)
- (1) - 10 lbs. pail of Heat Stop II refractory clay
- (75) - fire brick 2<sup>1</sup>/<sub>2</sub>" thick
- (1) - 47" x 3<sup>1</sup>/<sub>2</sub>" x 3<sup>1</sup>/<sub>2</sub>" steel lintel
- (2) - 42" x 3<sup>1</sup>/<sub>2</sub>" x 3<sup>1</sup>/<sub>2</sub>" steel lintels
- (1 left and 1 right) - Summit Stone (7<sup>1</sup>/<sub>4</sub>" x 3<sup>5</sup>/<sub>8</sub>" x 10<sup>7</sup>/<sub>8</sub>") special cut lintel pad unit
- (2) - Summit Stone (7<sup>1</sup>/<sub>4</sub>" x 3<sup>5</sup>/<sub>8</sub>" x 10<sup>7</sup>/<sub>8</sub>") units special cut common grooved lintel pad

• In addition to the double woodbox fireplace components listed above, 500 Summit Stone (7<sup>1</sup>/<sub>4</sub>" x 3<sup>5</sup>/<sub>8</sub>" x 10<sup>7</sup>/<sub>8</sub>") are needed to complete project.

• Concrete adhesive is sold separately. Approx. 10-12 tubes of adhesive will be required, depending on the quantity applied to each Summit Stone.

Approx. 12,000 lbs. - 5 total pallets

Product	Size D x H x L (inches)
Summit Fireplace Double Woodbox	54 x 79 <sup>3</sup> / <sub>4</sub> x 141 <sup>3</sup> / <sub>8</sub>

**Disclaimer:** This is a basic outdoor fireplace kit design. Outdoor fireplaces should always be constructed by a knowledgeable professional. Location, chimney height, flue size and prevailing winds can affect the performance of an outdoor fireplace. County Materials cannot guarantee the performance or structural integrity of this fireplace. Use only industry accepted materials, cements and adhesives when constructing an outdoor fireplace. Always observe building codes and local bylaws.



## Summit Stone Corner Fireplace



Product	Size D x H x L (inches)
Summit Fireplace Corner	82 x 79 3/4 x 104

### Corner Fireplace components include:

- (20) - 8" 1/4 concrete block
  - (5) - 6" concrete block
  - (20) - 4" concrete block
  - (5) - 3" soaps
  - (54) - Summit Stone (7 1/4" x 3 5/8" x 10 7/8") units special cut (1/3 and 2/3)
  - (1) - 10 lbs. pail of Heat Stop II refractory clay
  - (75) - fire brick 2 1/2" thick
  - (1) - 47" x 3 1/2" x 3 1/2" steel lintel
  - (1 left and 1 right) - Summit Stone (7 1/4" x 3 5/8" x 10 7/8") special cut lintel pad unit
  - (2) - Summit Stone (7 1/4" x 3 5/8" x 10 7/8") units special cut common grooved lintel pad
- In addition to the corner fireplace components listed above, 420 Summit Stone (7 1/4" x 3 5/8" x 10 7/8") are needed to complete project.
  - Concrete adhesive is sold separately. Approx. 10-12 tubes of adhesive will be required, depending on the quantity applied to each Summit Stone.

Approx. 10,320 lbs. - 4 total pallets

## Fire Pits and Serpentine Wall Designs Summit Stone Landscape Units

### Summit Stone Circular Fire Pit Design



Shown with optional Steel Fire Pit Insert

### Summit Stone G Tapered Unit

The Summit Stone G Tapered Unit can be used to design circular or square Fire Pits and Serpentine Walls. The G Tapered Unit is available in 4 colors (Haven, Hush, Solace and Timeless) and sold by the unit.

#### 36" Diameter Fire Pit Design Estimate

- (17) "G" units per layer
- 54" outside and 39" inside diameters

#### 42" Diameter Fire Pit Design Estimate

- (17) "G" units and 2 "A" units per layer
- 59" outside and 44" inside diameters

#### 48" Diameter Fire Pit Design Estimate

- (16) "G" units and (6) "A" units per layer
- 66" outside and 51" inside diameters

#### Larger Diameter Fire Pits

Larger diameter firepit designs can be accommodated if desired by adding additional "G" and "A" units per layer.

### Summit Stone Square Fire Pit Design



Shown with optional Square Steel Fire Pit Insert

#### 36" Square Fire Pit Design Estimate

- 3 layers high (30) "A" units, (12) "B" units and (12) "C" units.
- 50.75" outside and 36.25" inside dimensions

- Optional Steel Fire Pit Inserts – Circular or Square (sold separately)
- Optional Firebrick splits (sold separately)
- Refer to Fire Pit Inserts on page 167

### Summit Stone 3' High Serpentine Wall Design





# Pillar Construction Summit Stone Landscape Units



## Decorative Pillars

Summit Stone® is designed to let you build decorative pillars as individual accents or in combination with small decorative walls. No cutting or fitting is required.

To make a pillar with Summit Stone, place units in alternating layers as shown in the illustration below. Make sure you build on level and well compacted ground and recommended base pad. (Ask a Summit Stone dealer for guidelines.)

Apply concrete adhesive between each course as you construct the pillar. Place adhesive on the touching ends and undersides of each cap unit.

The hollow area inside of each pillar can accommodate electrical conduit for a light or a wood 4" x 4" to support a trellis, a lamp post or a garden gate.

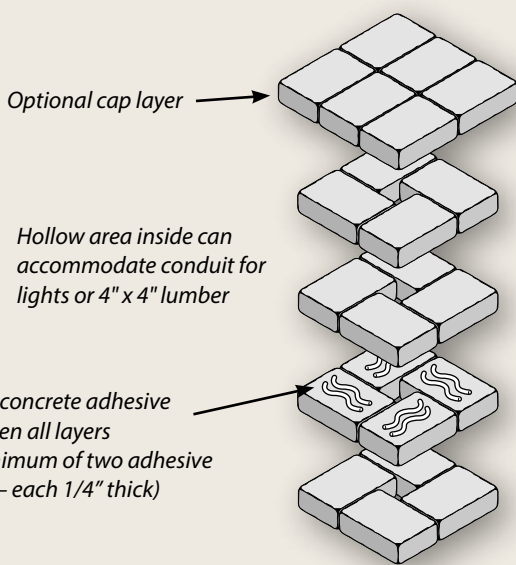

**NOTE:** Outside measurements of cap layer will be approximately 22" x 22". Post and wall heights should not exceed 36". For decorative walls, columns and steps, 1 to 2 layers of Summit Stone units should be buried below grade for proper embedment.



## Pillars with Electrical Conduit

- Sonotube must be placed 4' below grade.
- 24" x 24" x 4" concrete base is joined to the sonotube column with rebar.
- Conduit is placed 12" – 18" below grade (min.).
- Place units in alternating layers as shown below.
- Build on level and well-compacted ground and recommended base pad.
- Apply concrete adhesive between each course.

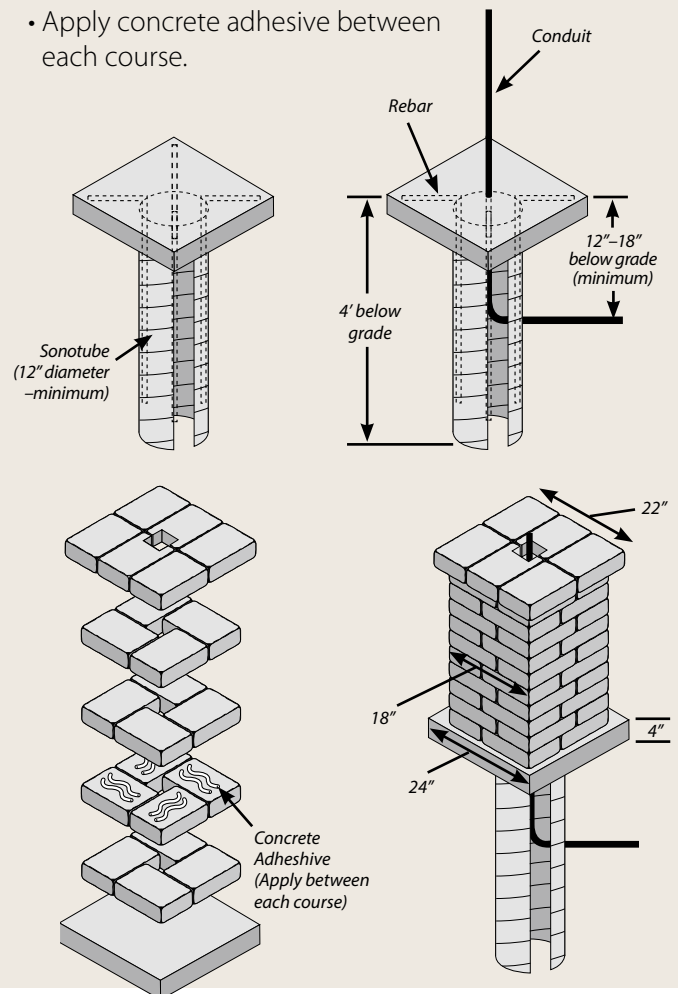



# Seat Walls, Alcoves and Tables Summit Stone Landscape Units



Summit Stone Landscape Units – Solace and Timeless with Grand Milestone Pavers – Serenity

## Seat Wall Patterns

Create Seat Walls that define the boundaries of your outdoor living patio spaces.

## Seat Walls: Formula for calculating Linear Feet

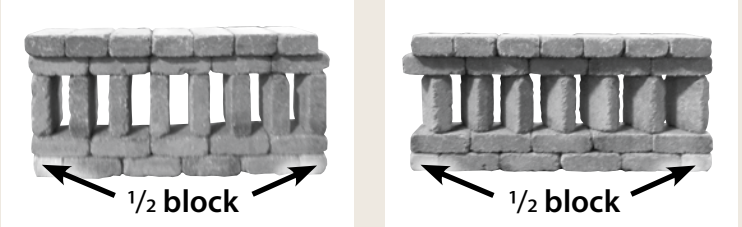

**7 block per lineal foot.**

Example: A 10-foot wall requires 70 block.

## Special Features: Surrounds/Alcoves for Grills, Refrigerators, etc.

### Enhance Your Outdoor Living Space

Outdoor kitchen appliances can be nestled into alcoves constructed of Summit Stone Tumbled Landscape Units, giving your outdoor living space an attractive, completed appearance.



### Alcove Layout #1

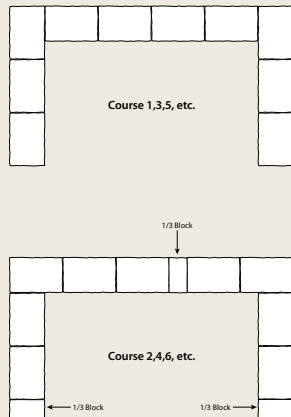

### Alcove Layout #2

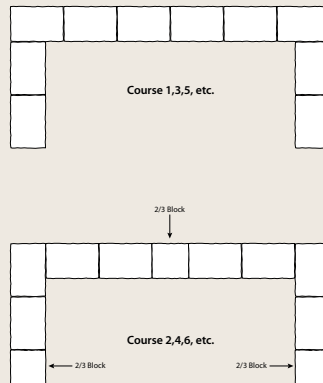

### Alcove Layout #3

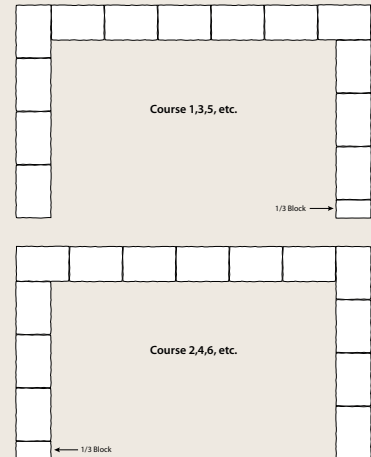

## Tables and Counters

Add functionality to your outdoor living space with a Summit Stone constructed table, storage space, bar, etc.



Summit Stone Landscape Units – Solace and Timeless with Grand Milestone Pavers – Serenity





Summit Stone Landscape Units – Hush and Haven



Summit Stone Landscape Units – Solace and Timeless with Grand Milestone Pavers – Serenity



Summit Stone Landscape Units – Hush and Haven



Summit Stone Landscape Units – Timeless, Tapered Retaining Wall Cap – Silvertone, Elements Paving Stones – Serenity (with Vision border) and Crest Bullnose Pavers – Reflection





Summit Stone Landscape Units – Timeless and Hush

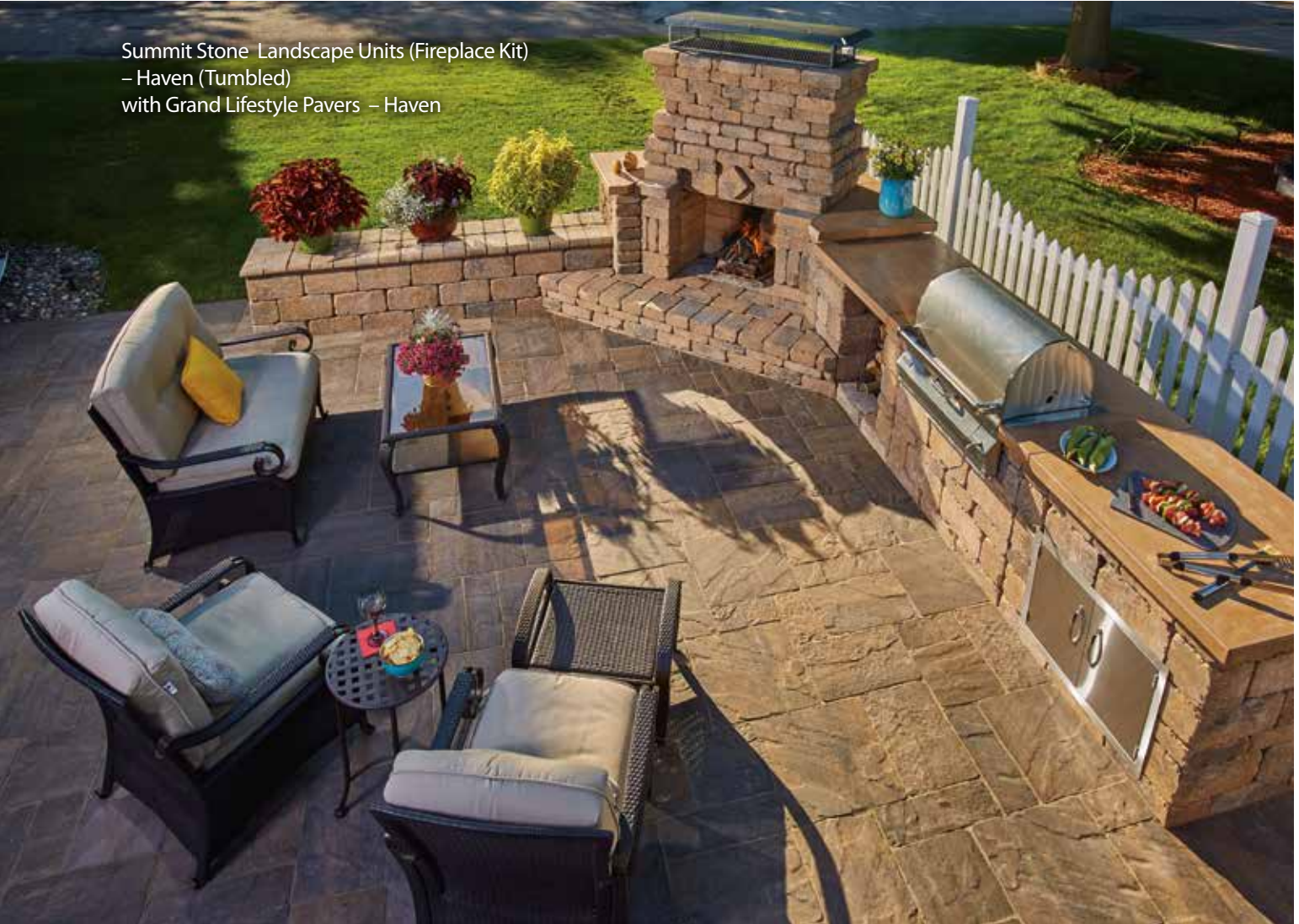

Summit Stone Landscape Units (Fireplace Kit)  
– Haven (Tumbled)  
with Grand Lifestyle Pavers – Haven



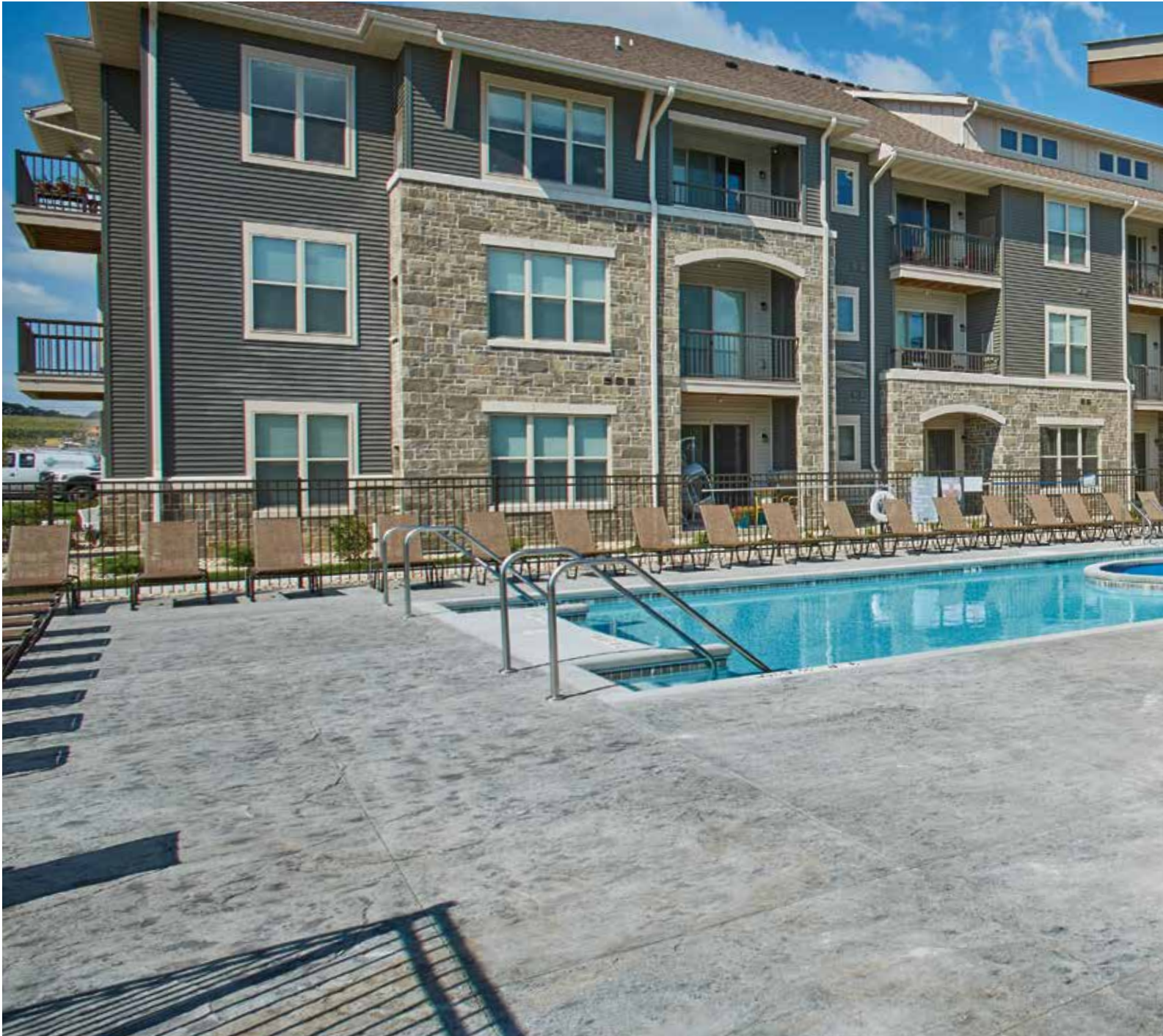



# Reflection Stone<sup>®</sup> Masonry Units

Reflection Stone Masonry Units combine the advantages of a high strength concrete veneer with the timeless character of natural hand-hewn stone.



Reflection Stone and Reflection Stone GRAND – Enchantment









Reflection Stone and Reflection Stone GRAND – Inspired

**Reflection Stone® Masonry Units** make an impression by mirroring the craftsmanship of centuries old stonework. County Materials' Reflection Stone line is available in three size modules: Reflection Stone, Reflection Stone GRAND and Reflection Brick. Each size can be installed as a stand-alone series or combined for custom applications. The Reflection Stone series is also available in full and thin veneer units, making them ideally suited for interior and exterior applications.

## Sizes **Reflection Stone Masonry Units • Full Veneer Units**

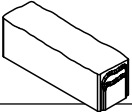
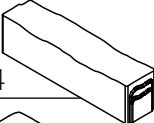
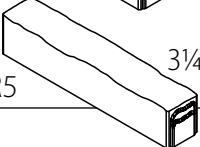
	H x D x L (Nominal Size) Inches • Millimeters
R1 	3¼ x 3¾ x 3¼ • 83 x 95 x 83
R2 	3¼ x 3¾ x 7 • 83 x 95 x 178
R3 	3¼ x 3¾ x 10¾ • 83 x 95 x 273
R4 	3¼ x 3¾ x 14½ • 83 x 95 x 369
R5 	3¼ x 3¾ x 18¼ • 83 x 95 x 464

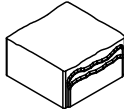
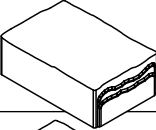
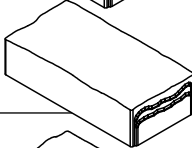
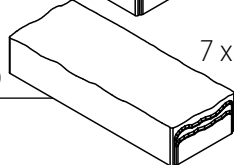
	H x D x L (Nominal Size) Inches • Millimeters
R6 	7 x 3¾ x 7 • 178 x 95 x 178
R7 	7 x 3¾ x 10¾ • 178 x 95 x 273
R8 	7 x 3¾ x 14½ • 178 x 95 x 369
R9 	7 x 3¾ x 18¼ • 178 x 95 x 464

SF/Layer	SF/Pallet	Lbs./Pallet
13.50	81	3280

Reflection Stone Masonry Units  
Pallet Layer

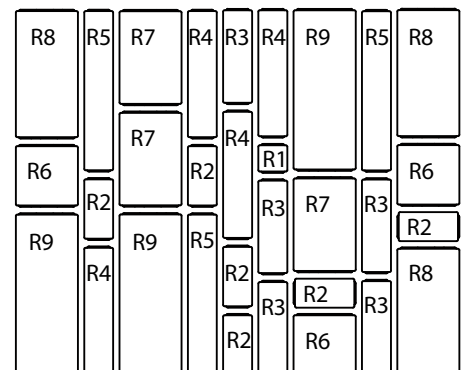





# Sizes Reflection Stone Masonry Units • Thin Veneers – Field Applied

## Faces

H x D x L (Nominal Size)  
Inches • Millimeters

RTV1  3¼ x 1 x 3¼ • 83 x 25 x 83

RTV2  3¼ x 1 x 7 • 83 x 25 x 178

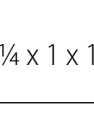
RTV3  3¼ x 1 x 10¾ • 83 x 25 x 273

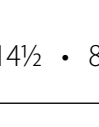
RTV4  3¼ x 1 x 14½ • 83 x 25 x 369

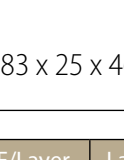
RTV5  3¼ x 1 x 18¼ • 83 x 25 x 464

H x D x L (Nominal Size)  
Inches • Millimeters

RTV6  7 x 1 x 7 • 178 x 25 x 178

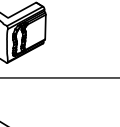
RTV7  7 x 1 x 10¾ • 178 x 25 x 273

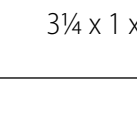
RTV8  7 x 1 x 14½ • 178 x 25 x 369

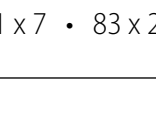
RTV9  7 x 1 x 18¼ • 178 x 25 x 464

SF/Layer	Layers/Pallet	SF/Pallet	Lbs/Pallet
13.5	10	135	1474

\* Reflection Stone thin veneer thickness will range from 3/4" to 1 1/4".

## Corners

H x D x L (Nominal Size)  
Inches • Millimeters

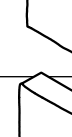
RTVC2  3¼ x 1 x 7 • 83 x 25 x 178

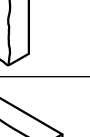
RTVC3  3¼ x 1 x 10¾ • 83 x 25 x 273

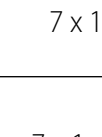
RTVC4  3¼ x 1 x 14½ • 83 x 25 x 369

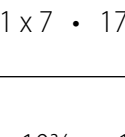
RTVC5  3¼ x 1 x 18¼ • 83 x 25 x 464

H x D x L (Nominal Size)  
Inches • Millimeters

RTVC6  7 x 1 x 7 • 178 x 25 x 178

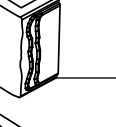
RTVC7  7 x 1 x 10¾ • 178 x 25 x 273

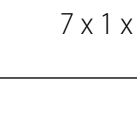
RTVC8  7 x 1 x 14½ • 178 x 25 x 369

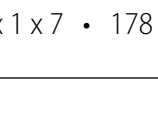
RTVC9  7 x 1 x 18¼ • 178 x 25 x 464

LF/Box	SF/Box	Lbs./Box
4.57	6.22	59

• Reflection Stone thin veneer thickness will range from 3/4" to 1 1/4".

• All Return Ends are 3 3/4" in depth.



## Sizes Reflection Stone GRAND Masonry Units • Full Veneer Units

H x D x L (Nominal Size)  
Inches • Millimeters

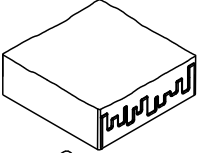
RG1   $10\frac{3}{4} \times 3\frac{3}{4} \times 10\frac{3}{4}$  • 273 x 95 x 273

---

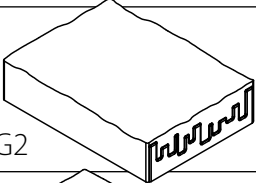
RG2   $10\frac{3}{4} \times 3\frac{3}{4} \times 14\frac{11}{16}$  • 273 x 95 x 373

---

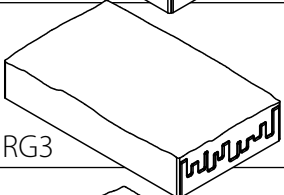
RG3   $10\frac{3}{4} \times 3\frac{3}{4} \times 18\frac{7}{16}$  • 273 x 95 x 468

---

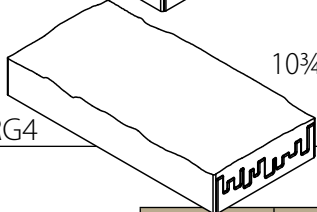
RG4   $10\frac{3}{4} \times 3\frac{3}{4} \times 22\frac{3}{16}$  • 273 x 95 x 563

SF/Layer	SF/Pallet	Lbs./Pallet
11	66	2617

Reflection Stone Grand  
Masonry Units Pallet Layer

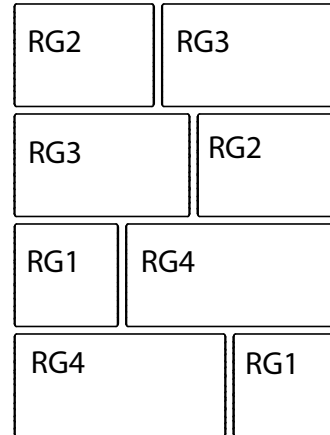

## Sizes Reflection Brick Masonry Units • Full Veneer Units

H x D x L (Nominal Size)  
Inches • Millimeters

RB2   $3\frac{1}{4} \times 3\frac{3}{4} \times 7$  • 83 x 95 x 178

---

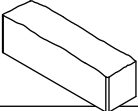
RB3   $3\frac{1}{4} \times 3\frac{3}{4} \times 10\frac{3}{4}$  • 83 x 95 x 273

---

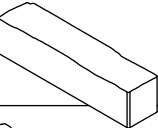
RB4   $3\frac{1}{4} \times 3\frac{3}{4} \times 14\frac{1}{2}$  • 83 x 95 x 369

---

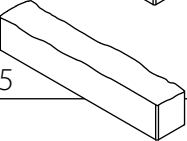
RB5   $3\frac{1}{4} \times 3\frac{3}{4} \times 18\frac{1}{4}$  • 83 x 95 x 464

SF/Layer	SF/Pallet	Lbs./Pallet
13.3	80	2940

Reflection Brick Masonry Units  
Pallet Layer

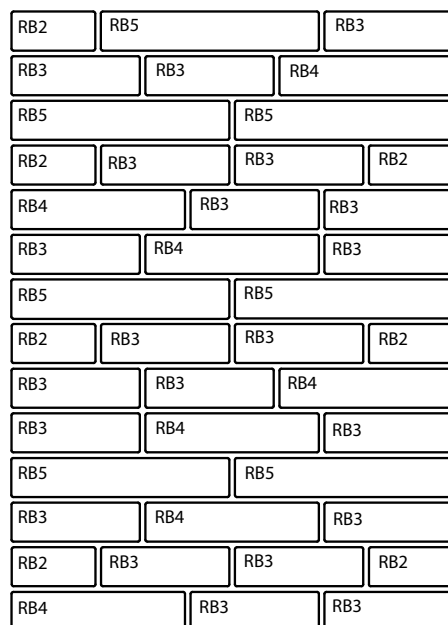



## Sizes Reflection Stone GRAND Masonry Units • Thin Veneers – Field Applied

### Faces

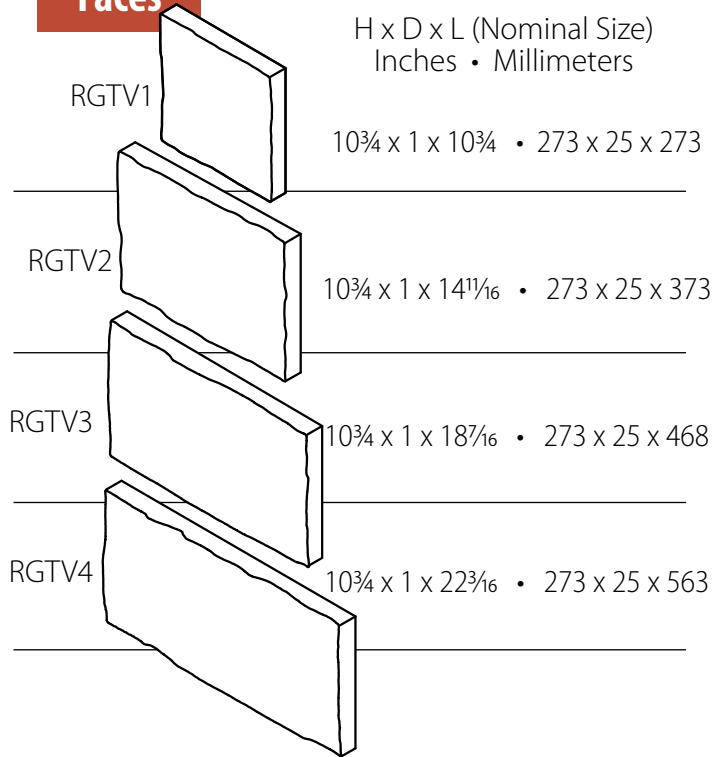

SF/Layer	Layers/Pallet	SF/Pallet	Lbs/Pallet
11	10	110	1412

### Corners

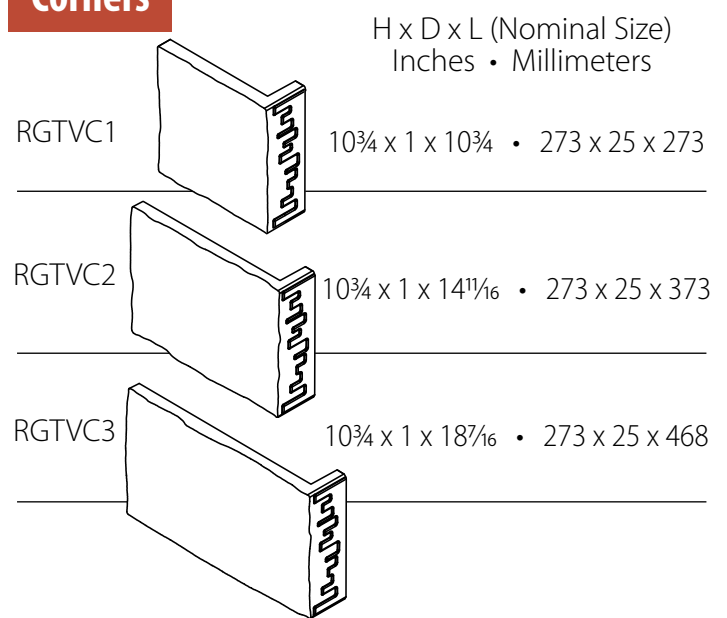

LF/Box	SF/Box	Lbs/Box
5.53	8.69	90

- Reflection Stone GRAND thin veneer thickness will range from 3/4" to 1 1/4".
- All Return Ends are 3 3/4" in depth.

## Sizes Reflection Brick Masonry Units • Thin Veneers – Field Applied

### Faces

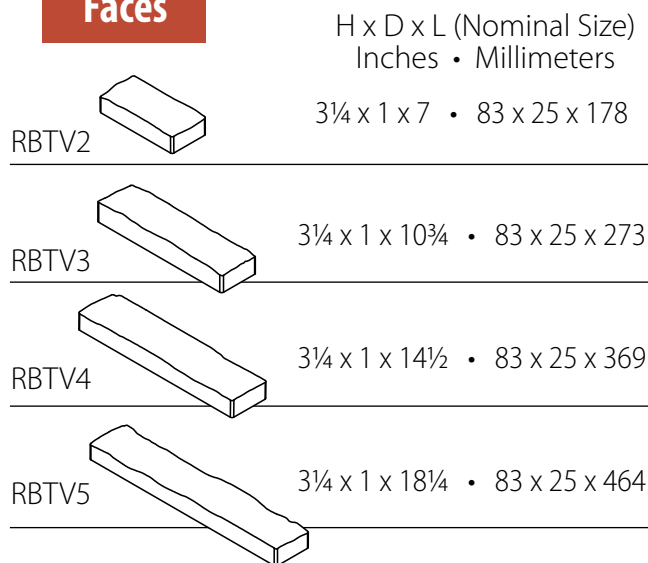

SF/Layer	Layers/Pallet	SF/Pallet	Lbs/Pallet
13.3	10	133	1604

### Corners

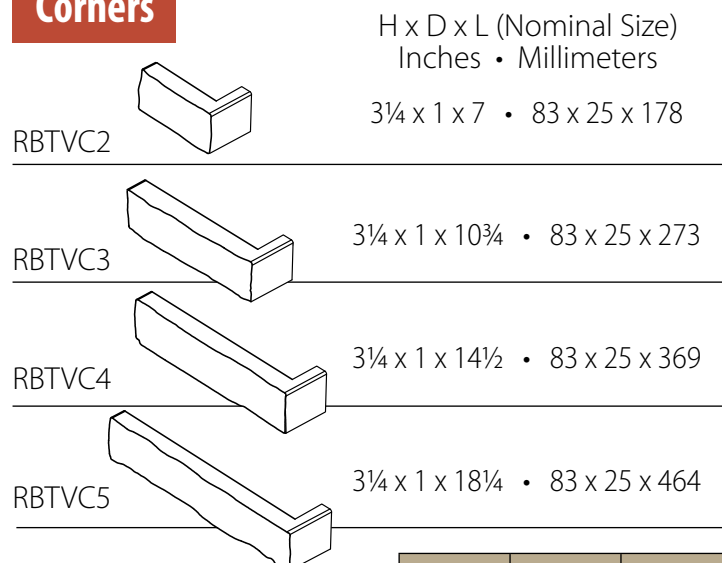

LF/Box	SF/Box	Lbs./Box
5.1	6.93	57

- Reflection Brick thin veneer thickness will range from 3/4" to 1 1/4".
- All Return Ends are 3 3/4" in depth.



# Color Options **Reflection Stone & Reflection Stone GRAND Masonry Units**

## Blended Colors

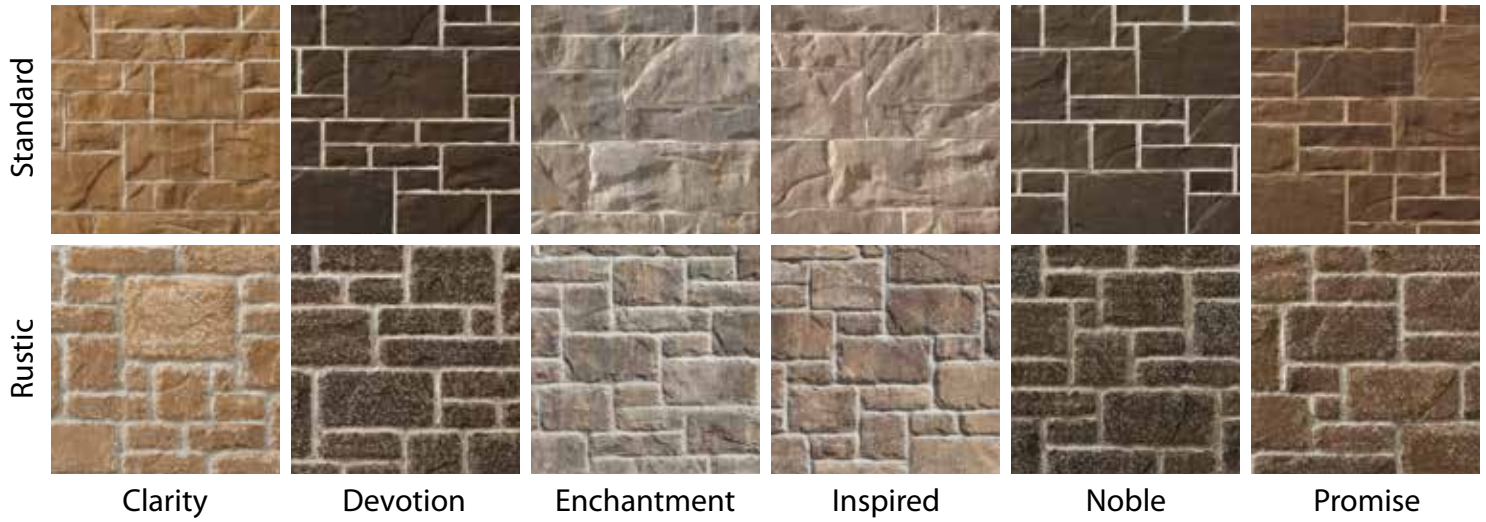

## Blended Colors

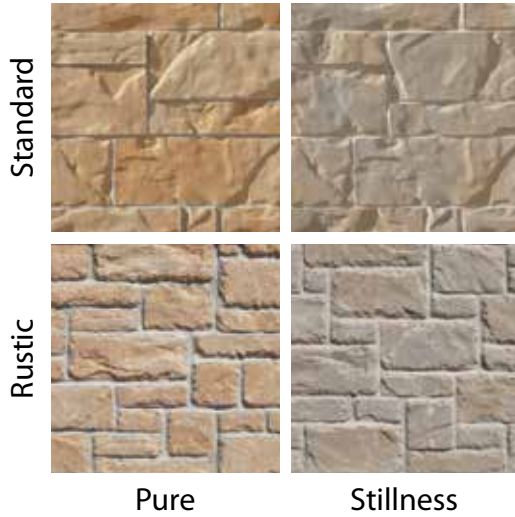

Reflection Stone and  
Reflection Stone GRAND – Enchantment



# Color Options **Reflection Brick Masonry Units**

## Blended Colors



## Blended Colors



*The color photos shown in this catalog were prepared with careful attention to accuracy. However, colors shown may vary from actual hues and should only be used as a guide. Refer to actual product samples for final color selection. Because concrete units are manufactured with high quality, naturally-mined aggregates and materials, variations in color or shading should be expected in products that are manufactured at different times and in units having different shapes. This color or shading variation is acceptable in the industry.*





# Isokern Fireplace, Oven & Chimney Components

After 70 years of unparalleled performance in the construction industry, Earthcore's Isokern line has become the most trusted modular system in the world. Isokern Fireplace & Chimney components are lightweight, while retaining UL 127 and UL 103HT (respectively) listings. Consequently, Isokern Fireplace & Chimney Systems are less expensive to install than traditional masonry fireplaces. And, unlike typical metal box fireplaces or concrete systems, they are built to last forever.

## Isokern Outdoor Fireplace Shell



(Nominal Size)



(Nominal Size)

Product	Size D x H x L (inches)	Units/Pallet	Lbs./Unit	Lbs./Pallet
Standard 36" Firebox	25¼ x 63¼ x 43	1	1205	1250
Standard 42" Firebox	25¼ x 63¼ x 49	1	1325	1370
Standard 46" Firebox	25¼ x 63¼ x 53	1	1450	1495

Product	Size D x H x L (inches)	Units/Pallet	Lbs./Unit	Lbs./Pallet
Magnum 36" Firebox	25¼ x 69¾ x 43	1	1300	1345
Magnum 42" Firebox	25¼ x 69¾ x 49	1	1420	1465
Magnum 46" Firebox	25¼ x 69¾ x 53	1	1600	1645

### Additional Products Offered:

Damper in 36", 42" and 48", Starter Flue, Inner Liner, Outer Casing, Offset Block, Black Rain Cap

## Isokern Oven & Chimney Components

### Iso'ven Table Top Kit



EM40 Mono Chimney

### DM54 Chimney System



Inner



Outer



Brick Ledge

Offset Block



DM Chimney Accessories



# Fire Pit Products

For additional information on Fire Pit construction, refer to Summit Stone Fire Pit Designs (on page 153).



**Corrugated Fire Pit Insert**



**Steel Fire Pit Insert – Square**



**Steel Fire Pit Insert – Circular**

## Manhole Block Fire Pit

*(No photo available)*

- Manhole Block 24" diameter ring requires 8 pieces, 8" high (sold per piece)
- Manhole Block 48" diameter ring requires 12 pieces, 8" high (sold per piece)

## Fire Pit Product Sizes

Product	Size
Corrugated Fire Pit Insert	36" Diameter
Steel Fire Pit Insert	36" Diameter
Steel Fire Pit Insert	42" Diameter
Steel Fire Pit Insert	48" Diameter
Square Steel Fire Pit Insert	36" Square
Manhole Block Fire Pit	24" Diameter
Manhole Block Fire Pit	48" Diameter



Natural Stone – Bulk Cobblestone  
with Elements Paving Stones – Timeless and Haven  
and Oversize Landscape Step Units – Camel





# Landscape Stone

- Natural Stone
- Bulk Cobblestone
- Outcropping Boulders
- Fond du Lac Outcropping Stone
- Natural Stone Drywall
- Natural Stone Steppers
- River Run® & Hidden Trails™ Bagged Landscape Products



*The color photos shown in this catalog were prepared with careful attention to accuracy. However, colors shown may vary from actual hues and should only be used as a guide. Refer to actual product samples for final color selection. Because concrete units are manufactured with high quality, naturally-mined aggregates and materials, variations in color or shading should be expected in products that are manufactured at different times and in units having different shapes. This color or shading variation is acceptable in the industry.*



## Natural Stone – Bulk Cobblestone/Fieldstone



Product	Size (inches)	SF/ Ton
Bulk Cobblestone	3 - 6	35
Bulk Cobblestone	4 - 8	35
Bulk Cobblestone	8 - 12	32
Bulk Cobblestone	12 - 18	20
Bulk Cobblestone	18 - 24	15
Bulk Cobblestone	24 - 36	10
Bulk Cobblestone	36 & Up	

**Note:** Product is sold by the ton

- Products also available in 2000 lb. and 3000 lb. Bags

## Natural Stone – Outcropping Boulders



Product	Lbs./Unit
Outcropping Fieldstone	1-2.5 tons
Outcropping Limestone	1-2.5 tons
Outcropping Basin Blue	1-2.5 tons

## Fond du Lac Outcropping Stone



**Note:** Product is sold by the ton

## Natural Stone Drywall



**Note:** Product is sold by the ton



## Natural Stone Steppers



**Note:** Product is sold by the ton

## Hidden Trails™ Bagged Landscape Products



Category	Product	Volume (cf)	Units/Pallet
Aggregate	American Heritage 1 1/2"	1/2	63
Sand & Soil	Top Soil	3/4	70
Sand & Soil	Potting Soil	3/4	70
Sand & Soil	Cow Manure Mix	1	75
Sand & Soil	Play Sand	1/2	63

## River Run® Bagged Landscape Products



Category	Product	Volume (cf)	Units/Pallet
Sand & Soil	White Play Sand	1/2	63
Sand & Soil	Mason Sand	1/2	63
Sand & Soil	Trac Sand	60 lbs.	54
Sand & Soil	Paver Base	1/2	63
Sand & Soil	Leveling Sand	1/2	63

Category	Product	Volume (cf)	Units/Pallet
Aggregate	American Heritage 3/4"	1/2	63
Aggregate	Glacier Bay 1 1/2"	1/2	63
Aggregate	Red Lava Rock	1	70
Aggregate	Pea Stone 3/8"	1/2	63
Aggregate	White Marble Stone	.4	77
Aggregate	River Cobble 2-3"	1/2	63
Aggregate	Western Sunset	1/2	84
Aggregate	Multi Purpose Gravel	1/2	63
Aggregate	Mountain Blend	1/2	63





# County Materials' Landscape & Masonry Locations:

## Antigo

908 Hickory St.  
Antigo, WI 54409  
715-623-3775

## Hazelhurst

6857 US Hwy 51  
Hazelhurst, WI 54531  
715-356-1174

## Oak Creek

7200 S 10th St.  
Oak Creek, WI 53154  
414-764-8700

## Tomahawk

407 S Tomahawk Ave.  
Tomahawk, WI 54487  
715-453-5463

## Appleton

3019 W Prospect Ave.  
Appleton, WI 54914  
920-734-7733

## Holmen

611 Empire St.  
Holmen, WI 54636  
608-526-9020

## Rice Lake

3200 S Main St.  
Rice Lake, WI 54868  
715-234-8145

## Waukesha

W229N2450 Homewood Ct.  
Waukesha, WI 53186  
262-896-0755

## Eau Claire

1111 Menomonie St.  
Eau Claire, WI 54702  
715-834-7701

## Madison

6399 Nesbitt Rd.  
Madison, WI 53719  
608-845-8636

## Roberts

1203 70th Ave.  
Roberts, WI 54023  
715-749-4121

## Weston

9303 Schofield Ave.  
Weston, WI 54476  
715-359-7731

## Green Bay

2448 Century Rd.  
Green Bay, WI 54303  
920-497-2416

## Marathon

205 North St.  
Marathon, WI 54448  
715-848-1365

## Stevens Point

2000 Patch St.  
Stevens Point, WI 54481  
715-341-0991

## Wisconsin Rapids

2310 N 40th St.  
Wisconsin Rapids, WI 54494  
715-423-7339

Contact Customer Service at (800) 242-7733 or visit our website at [www.countymaterials.com](http://www.countymaterials.com) for additional information about County Materials' Dealer Locations.

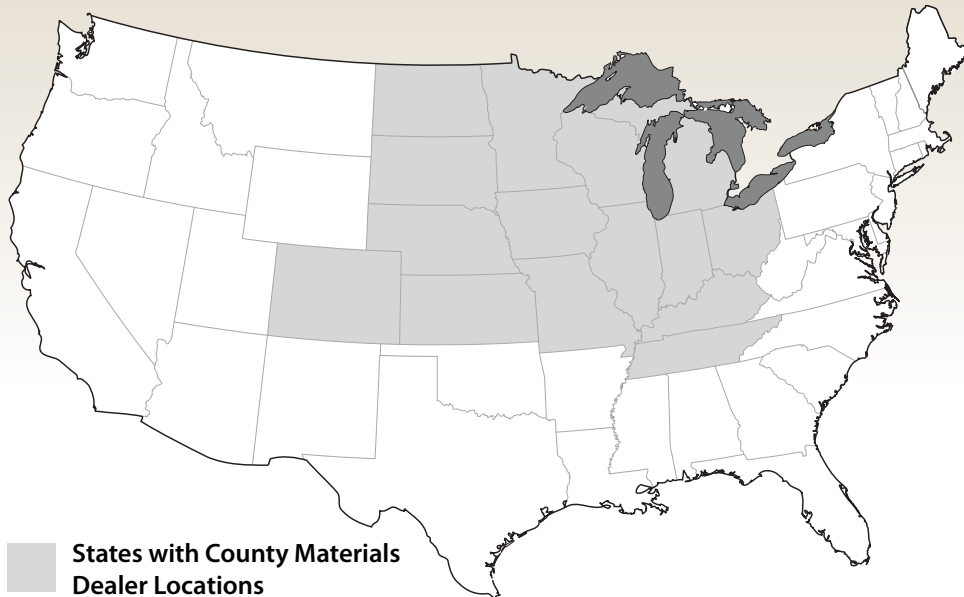

We value your business. Please contact your County Materials' representative for specific information on products and their availability in your area.



*The color photos shown in this catalog were prepared with careful attention to accuracy. However, colors shown may vary from actual hues and should only be used as a guide. Refer to actual product samples for final color selection. Because concrete units are manufactured with high quality, naturally-mined aggregates and materials, variations in color or shading should be expected in products that are manufactured at different times and in units having different shapes. This color or shading variation is acceptable in the industry.*



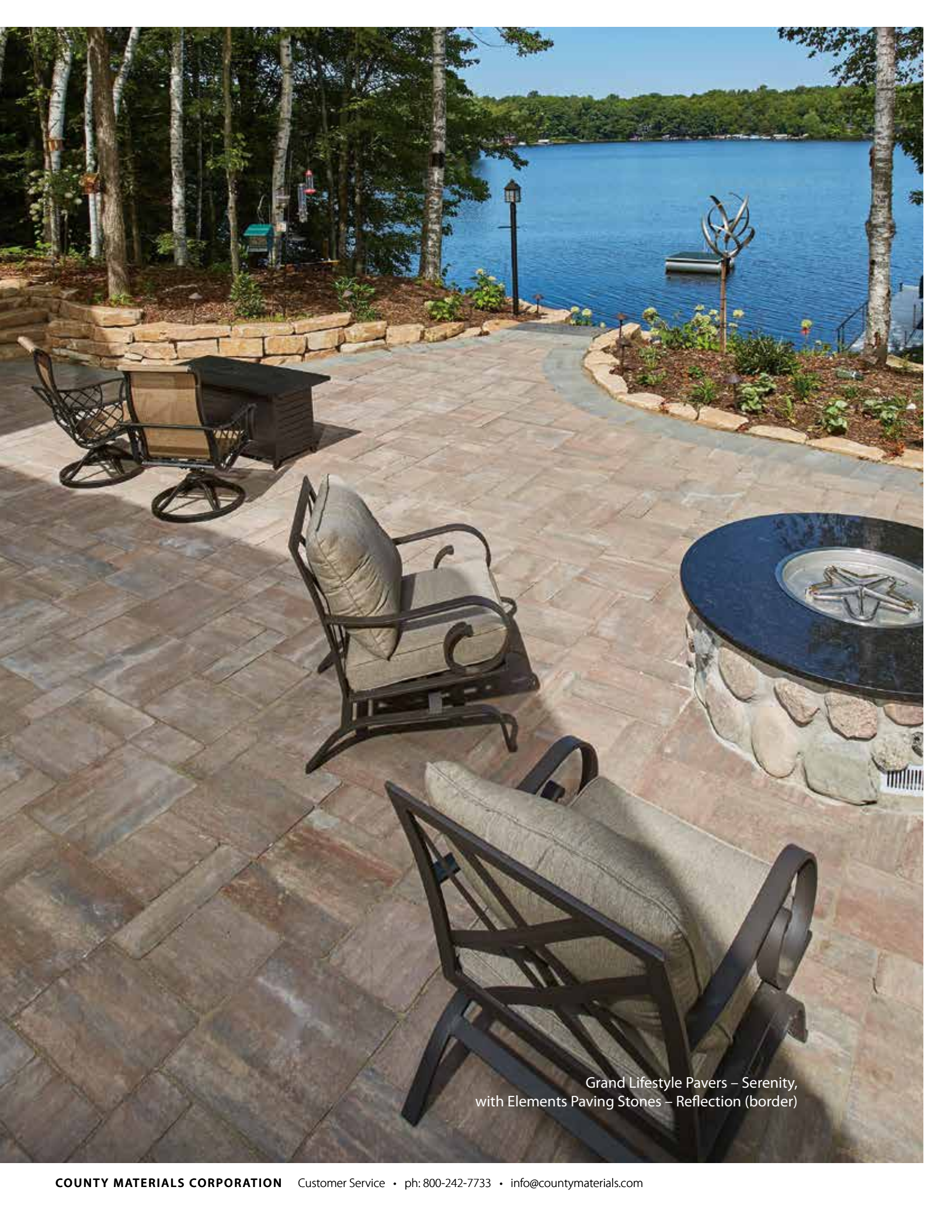

Grand Lifestyle Pavers – Serenity,  
with Elements Paving Stones – Reflection (border)





©2019 County Materials Corporation 0794\_0219